

SCHEDA RADIOFREQUENZA
RADIO-FREQUENCY BOARD
CARTE RADIOFRÉQUENCE
RADIOFREQUENZKARTEN
TARJETA RADIOFRECUENCIA

AF43SM

ITALIANO

CARATTERISTICHE TECNICHE

Scheda di radiofrequenza a 433.92 MHz, dotata di memoria EEprom in grado di memorizzare fino a 128 codici diversi.

E' compatibile con i trasmettitori della serie TOP super-reattiva e TAM. Può essere inserita su tutti i quadri o schede di comando CAME, direttamente (in quelli di nuova generazione) o abbinata ad una scheda RBI o RBE (per tutti gli altri). Il comando può essere indirizzato, in alternativa, sull' uscita CH1 o CH2.

Trasforma i normali ricevitori radio monoutente in ricevitori multiutente e permette, anche a distanza di tempo, una veloce e rapida manutenzione dell'impianto (cancellazione/ripristino aggiunta o modifica).

E' adatto, in particolar modo, alle applicazioni su condomini dove coesistono utenze comuni (cancello o sbarra di ingresso all'area condominiale) e utenze singole (basculante garage).

Comprende anche una schedina di Backup per fare una copia di sicurezza di tutti i 128 codici immessi.

PRINCIPALI COMPONENTI

1. Dip-switch selezione codici e funzioni
2. Pulsante attivazione funzioni
3. Led rosso di segnalazione
4. Led verde di segnalazione
5. Schedina di Backup
6. Connettore innesto su ricevitori

ISTRUZIONI - INSTALLAZIONE

CAP.A	PAG. 3	CODIFICARE I TRASMETTITORI
CAP.B	PAG. 4	COMPILARE UNA DISTINTA NUMERATA DEI TRASMETTITORI
CAP.C	PAG. 6	REGISTRARE I CODICI SULLA SCHEDINA AF43sM
CAP.D	PAG. 8	TRASFERIRE I CODICI ALLA SCHEDA BASE DEL RICEVITORE

ISTRUZIONI - MANUTENZIONE

MAN1	PAG. 9	CANCELLAZIONE SINGOLI CODICI
MAN2	PAG. 10	CANCELLAZIONE INTERA MEMORIA
MAN3	PAG. 11	AGGIUNTA DI CODICI
MAN4	PAG. 11	MODIFICA CODICI
MAN5	PAG. 12	RECUPERO SINGOLI CODICI
MAN6	PAG. 13	RECUPERO INTERA MEMORIA
MAN7	PAG. 14	COPIA DI SICUREZZA DEI CODICI MEMORIZZATI (BACKUP)
MAN8	PAG. 15	REINSTALLAZIONE DEI CODICI MEMORIZZATI DALLA COPIA DI SICUREZZA (RESTORE)

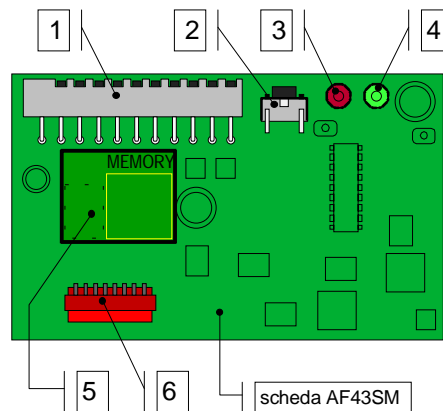

ENGLISH

TECHNICAL PARTICULARS

433.92 MHz RF board fitted with EEprom memory capable of storing up to 128 different codes.

It is compatible with the TOP superreactive and TAM series transmitters. It can be fitted on all CAME control panels or boards, either directly (in the new generation ones) or together with an RBI or RBE board (for all the others). The control can be addressed on either the CH1 or CH2 output.

It transforms the normal single-user receivers into multi-user ones and makes for quick system maintenance (deletion/restoring addition or editing), even after some time.

It is particularly suitable for applications in blocks of flats where communal facilities (entrance gate or barrier) coexist with individual facilities (garage door). It also includes a backup board for creating a backup copy of all the 128 codes entered.

MAIN COMPONENTS

1. Dip-switches for code and function selection
2. Function enabling button
3. Red signalling LED
4. Green signalling LED
5. Backup board
6. Plug-in connector on receivers

INSTRUCTIONS - INSTALLATION

CHAP.A	PAGE 3	CODING TRANSMITTERS
CHAP.B	PAGE 4	DRAWING UP A NUMBERED LIST OF TRANSMITTERS
CHAP.C	PAGE 6	RECORDING THE CODES ON THE AF43sM BOARD
CHAP.D	PAGE 8	TRANSFERRING THE CODES TO THE RECEIVER'S STANDARD BOARD

INSTRUCTIONS - MAINTENANCE

MAN1	PAGE 9	DELETING INDIVIDUAL CODES
MAN2	PAGE 10	ERASING THE WHOLE MEMORY
MAN3	PAGE 11	ADDING CODES
MAN4	PAGE 11	EDITING CODES
MAN5	PAGE 12	RESTORING INDIVIDUAL CODES
MAN6	PAGE 13	RESTORING THE WHOLE MEMORY
MAN7	PAGE 14	BACKUP COPY OF THE CODES SAVED
MAN8	PAGE 15	REINSTALLING THE CODES SAVED BY THE BACKUP COPY

CARACTÉRISTIQUES TECHNIQUES

Carte de radiofréquence à 433.92 MHz, munie de mémoire EEprom en mesure de mémoriser jusqu'à 128 codes différents.

Elle est compatible avec les émetteurs de la série TOP super-réactive et TAM. Elle peut être installée directement sur tous les armoires ou cartes de commande CAME (ceux de la nouvelle génération) ou bien être associée à une carte RBI ou RBE (pour les autres). La commande peut être envoyée aussi bien sur la sortie CH1 que sur la sortie CH2.

Elle transforme les récepteurs radio normaux pour une seule utilisation en récepteurs pour utilisations multiples et permet un entretien facile et rapide de l'installation, même au bout d'un certain temps (annulation/ reprise, adjonction ou modification).

Elle est particulièrement indiquée dans les immeubles collectifs d'habitation avec motorisation en commun (portail ou barre d'entrée) et motorisation individuelle (porte basculante de garage).

Elle contient également une carte de Backup permettant de faire une copie de sauvegarde des 128 codes saisis.

PRINCIPAUX COMPOSANTS

1. Commutateur à bascule sélection codes et fonctions
2. Bouton d'activation des fonctions
3. Led rouge de signalisation
4. Led vert de signalisation
5. Carte de sauvegarde (Backup)
6. Connecteur branchement sur récepteurs

INSTRUCTIONS - INSTALLATION

CHAP.A	PAGE 3	CODIFIER LES ÉMETTEURS
CHAP.B	PAGE 4	REMPILIR UNE LISTE NUMÉROTÉE DES ÉMETTEURS
CHAP.C	PAGE 6	ENREGISTRER LES CODES SUR LA CARTE AF43sM
CHAP.D	PAGE 8	TRANSFÉRER LES CODES A LA CARTE BASE DU RÉCEPTEUR

INSTRUCTIONS - ENTRETIEN

MAN1	PAGE 9	ANNULATION DES DIFFÉRENTS CODES
MAN2	PAGE 10	ANNULATION DE TOUTE LA MÉMOIRE
MAN3	PAGE 11	ADJONCTION DE CODES
MAN4	PAGE 11	MODIFICATION DE CODES
MAN5	PAGE 12	RÉCUPÉRATION DES DIFFÉRENTS CODES
MAN6	PAGE 13	RÉCUPÉRATION DE TOUTE LA MÉMOIRE
MAN7	PAGE 14	COPIE DE SAUVEGARDE DES CODES MÉMORISÉS (BACKUP)
MAN8	PAGE 15	RÉINSTALLATION DES CODES MÉMORISÉS PAR LA COPIE DE SAUVEGARDE (RESTORE)

TECHNISCHE DATEN

Radiofrequenzkarte mit 433,92 MHz und EEprom-Speicher, in dem bis zu 128 verschiedene Codes gespeichert werden können.

Kompatibel mit den Sendern der Serie TOP Superreaktiv und TAM. Kann in alle Schaltkästen oder Steuerungskarten von CAME eingesetzt werden, und zwar direkt (in der neuen Generation) oder in Kombination mit einer RBI- oder RBE-Karte (alle anderen Versionen). Die Steuerung kann alternativ auch auf die Ausgänge CH1 oder CH2 gelegt werden.

Mit der Radiofrequenzkarte werden aus den normalen Empfängern für Einzelbenutzung Empfänger für Mehrfachbenutzung. Außerdem ist so eine schnelle Wartung der Anlage möglich (Löschen/Reset von Ergänzungen oder Veränderungen), auch nach längerer Zeit.

Die Radiofrequenzkarte eignet sich besonders für den Einsatz in Wohnhäusern mit gemeinsamen Anwendungsbereichen (Tor oder Schranke am Eingang zum Wohnbereich) und individuellen Anwendungsbereichen (Kipptor Garage).

Inklusive Backup-Karte für eine Sicherungskopie der 128 eingegebenen Codes.

DIE WICHTIGSTEN KOMPONENTEN

1. Dip-switch zur Wahl von Codes und Funktionen
2. Startknopf Funktionen
3. rote Kontrollleuchte
4. grüne Kontrollleuchte
5. Backup-Karte
6. Steckvorrichtung auf Empfängern

INSTALLATIONSANLEITUNGEN

KAP.A	S. 3	KODIEREN DER SENDER
KAP.B	S. 4	ERSTELLEN EINES NUMERIERTEN VERZEICHNISSES DER SENDER
KAP.C	S. 6	EINGABE DER CODES AUF DER KARTE AF43sM
KAP.D	S. 8	ÜBERTRAGUNG DER CODES AUF DIE BASISKARTE DES EMPFÄNGERS

WARTUNGSANLEITUNGEN

MAN1	S. 9	LÖSCHEN EINZELNER CODES
MAN2	S. 10	LÖSCHEN DES GESAMTEN SPEICHERS
MAN3	S. 11	ERGÄNZUNG VON CODES
MAN4	S. 11	VERÄNDERUNG VON CODES
MAN5	S. 12	RETTEN EINZELNER CODES
MAN6	S. 13	RETTEN DES GESAMTEN SPEICHERS
MAN7	S. 14	SICHERUNGSKOPIE DER GESPEICHERTEN CODES (BACKUP)
MAN8	S. 15	NEUEINGABE DER GESPEICHERTEN CODES VON DER SICHERUNGSKOPIE AUS (RESTORE)

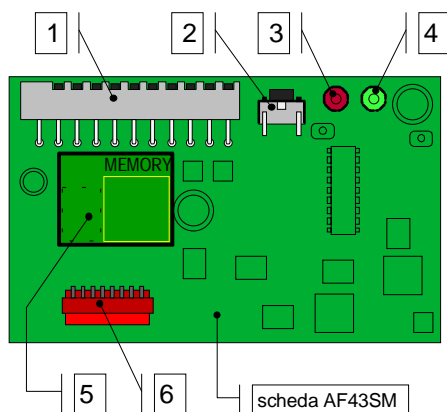

CARACTERÍSTICAS TÉCNICAS

Tarjeta de radiofrecuencia de 433.92 MHz, dotada de memoria EEprom capaz de almacenar hasta 128 códigos diferentes.

Es compatible con los transmisores de la serie TOP superreactiva y TAM. Puede instalarse en cualquier cuadro o tarjeta de mando CAME, directamente (en las más recientes) o utilizarse junto con una tarjeta RBI o RBE (para todas las demás). En alternativa, el mando puede dirigirse a la salida CH1 o CH2.

Convierte los normales radiorreceptores monousuario en receptores multiusuario consintiendo, incluso después de mucho tiempo, un mantenimiento rápido de la instalación (operaciones de borrado/restablecimiento, añadidos o modificaciones).

Es especialmente apta para aplicaciones en comunidades donde haya al mismo tiempo usuarios comunes (verja o barra de entrada al área de la comunidad) y usuarios particulares (puerta basculante garaje).

Incluye una tarjeta de backup para realizar una copia de seguridad de los 128 códigos introducidos.

COMPONENTES PRINCIPALES

1. Dip-switch selección códigos y funciones
2. Botón de activación funciones
3. Led rojo de señalización
4. Led verde de señalización
5. Tarjeta de backup
6. Conector acoplamiento en receptores

INSTRUCCIONES - INSTALACIÓN

CAP.A	PÁG. 3	CODIFICAR LOS TRANSMISORES
CAP.B	PÁG. 4	RELLENAR UNA LISTA NUMERADA DE TRANSMISORES
CAP.C	PÁG. 6	REGISTRAR LOS CÓDIGOS EN LA TARJETA AF43sM
CAP.D	PÁG. 8	TRANSFERIR LOS CÓDIGOS S LA TARJETA BASE DEL RECEPTOR

INSTRUCCIONES - MANTENIMIENTO

MAN1	PÁG. 9	BORRADO DE CÓDIGOS POR SEPARADO
MAN2	PÁG. 10	BORRADO TOTAL DE LA MEMORIA
MAN3	PÁG. 11	AÑADIDO DE CÓDIGOS
MAN4	PÁG. 11	MODIFICACIÓN DE CÓDIGOS
MAN5	PÁG. 12	RECUPERACIÓN DE CÓDIGOS POR SEPARADO
MAN6	PÁG. 13	RECUPERACIÓN DE LA MEMORIA ENTERA
MAN7	PÁG. 14	COPIA DE SEGURIDAD DE LOS CÓDIGOS ALMACENADOS (BACKUP)
MAN8	PAG. 15	REINSTALACIÓN DE LOS CÓDIGOS ALMACENADOS DESDE LA COPIA DE SEGURIDAD (RESTORE)

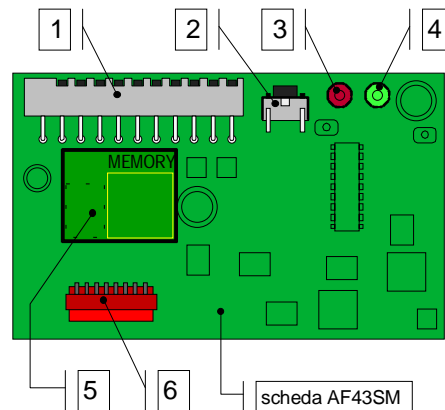

A

ITALIANO

A - CODIFICA TRASMETTITORI

Codificare ogni trasmettitore (o gruppo di trasmettitori) assegnato a una famiglia o appartamento, con un codice diverso.

Consultare, per ogni tipo di trasmettitore, la relativa documentazione fornita con il prodotto.

In un impianto (condominio) possono coesistere solo trasmettitori della stessa serie (TOP o TAM).

Fam. ROSSI
codice A



Fam. VERDI
codice B



Fam.
codice ...



ENGLISH

A - CODING TRANSMITTERS

Code each transmitter (or group of transmitters), assigned to a family or flat, with a different code.

Consult the relevant documents supplied with the product for each type of transmitter.

Only transmitters from the same series (TOP or TAM) can coexist in a single system (block of flats).

FRANCAIS

A - CODIFICATION EMETTEURS

Codifier chaque émetteur (ou groupe d'émetteurs) attribué à une famille ou à un appartement, avec un code différent. Pour chaque type d'émetteur, consulter la documentation correspondante fournie avec le produit.

Il ne peut y avoir que des émetteurs de la même série (TOP ou TAM) dans la même installation (immeuble).

DEUTSCH

A - KODIEREN DER SENDER

Jeder Sender (oder Sendeeinheit) wird mit einem anderen Code kodiert und einer Familie oder einer Wohnung zugeordnet.

Schlagen Sie für jeden Sendertyp im entsprechenden Handbuch nach, das zum Produkt gehört.

In einer Anlage (Wohnhaus) dürfen nur Sender der gleichen Serie verwendet werden (TOP oder TAM).

ESPAÑOL

A - CODIFICAR LOS TRANSMISORES

Codificar cada transmisor (o grupo de transmisores) asignado a una familia o vivienda, con un código distinto.

Para cada tipo de transmisor, consultar la documentación adjunta al producto. En una instalación (comunidad) pueden coexistir sólo transmisores de la misma serie (TOP ó TAM).

ITALIANO

B - DISTINTA CODICI

Compilare ora la **lista numerata**, di seguito predisposta, per associare ogni gruppo di trasmettitori a un nome di famiglia, di appartamento o di numero civico.

Attenzione! la posizione numerica (1) progressiva indica l'ordine sequenziale con cui si dovrà procedere alle successive operazioni di REGISTRAZIONE CODICI (cap. C).

La combinazione (2) dei dip 1÷7 associata ad ogni posizione numerica della lista, che non è il codice del trasmettitore, indica la posizione fisica nel chip dove verrà memorizzato il codice ed è fissa. Servirà nel momento in cui si dovrà procedere a qualche intervento successivo (Es.: modifica codice per un cambio di locazione).

La lista così compilata, assieme alla schedina di backup, deve essere conservata dall'installatore e/o dall'amministratore del condominio.

ENGLISH

B - CODE LIST

Now draw up the **numbered list**, set out below, in order to associate each group of transmitters with a family name, flat or house number.

Caution! The progressive numerical position (1) indicates the sequential order in which the subsequent CODE RECORDING operations must be carried out (chap. C).

The combination (2) of the dip-switches 1÷7 associated with each numerical position on the list, which is not the transmitter code, indicates the physical position in the chip where the code will be saved, and is fixed. It will be required when any subsequent operations must be carried out (e.g. editing codes owing to a change in location).

The resulting list, together with the backup board, must be kept by the installer and/or the building's administrator.

FRANCAIS

B - LISTE DES CODES

Remplir ensuite la **liste numérotée**, prévue ci-dessous, pour associer chaque groupe d'émetteurs à un nom de famille, d'appartement ou de numéro de rue.

Attention! la position numérique (1) progressive indique l'ordre séquentiel selon lequel il faudra ensuite effectuer les opérations d'ENREGISTREMENT DE CODES (chap. C).

La combinaison (2) des dips 1÷7 associée à chaque numéro de la liste, qui n'est pas le code de l'émetteur, est fixe et indique la position physique dans le circuit intégré où le code sera mémorisé. Elle servira au moment où il faudra effectuer une autre intervention quelconque (Ex.: modification du code pour un changement de location).

L'installateur et/ou l'administrateur de l'immeuble devra conserver la liste ainsi remplie ainsi que la carte de sauvegarde.

DEUTSCH

B - VERZEICHNIS CODES

Erstellen Sie jetzt ein **numeriertes Verzeichnis** für den späteren Gebrauch und ordnen Sie dabei jeder Sendeeinheit einen Familiennamen, eine Wohnung oder eine Hausnummer zu.

Achtung! Die fortlaufende Numerierung (1) gibt die Reihenfolge an, in der bei der späteren EINGABE DER CODES (Kap. C) vorgegangen werden muß.

Die Kombination (2) der Dip-Schalter 1 bis 7, die jeder Position des Verzeichnisses zugeordnet ist, bei der es sich nicht um den Sendercode handelt, gibt die physikalische Position auf dem Chip an, in der der Code gespeichert wird. Diese Kombination ist fix und wird später benötigt, wenn die Codes bearbeitet werden müssen (z.B. Änderung eines Codes wegen Standortwechsel).

Das so erstellte Verzeichnis muß zusammen mit der Backup-Karte vom Installateur u/o Verwalter des Wohnhauses aufbewahrt werden.

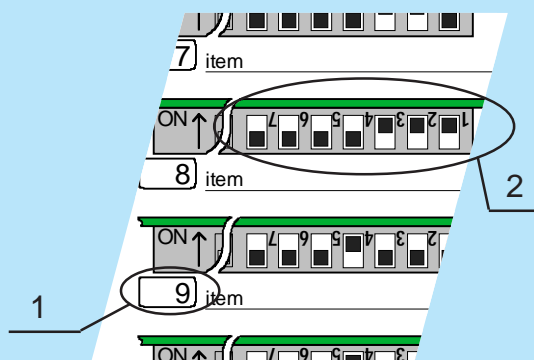
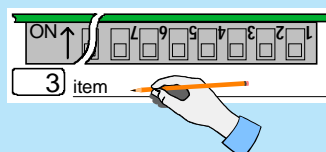
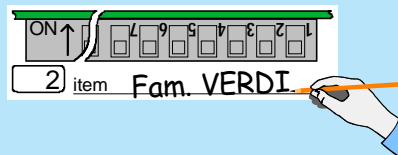
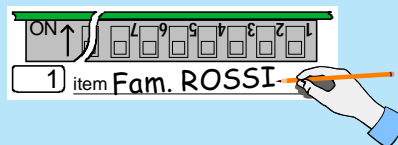

ESPAÑOL

B - LISTA DE CÓDIGOS













































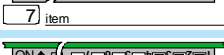
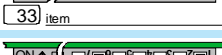

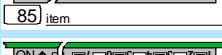
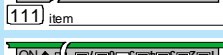

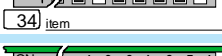

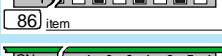

































































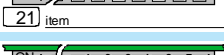
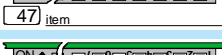
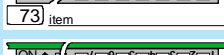
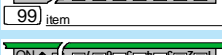
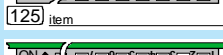

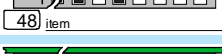

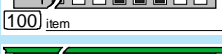
Rellenar la **lista numerada**, facilitada a continuación, para asociar cada grupo de transmisores a un nombre de familia, vivienda o número civico.

¡Atención! la posición numérica (1) progresiva indica el orden secuencial al que atenerse en las sucesivas operaciones de REGISTRO DE CÓDIGOS (cap. C).

La asociación (2) de los dip 1÷7 con la relativa posición numérica en la lista, que no es el código del transmisor, indica la posición física en el chip donde se almacenará el código y es fija. Se utilizará durante posibles intervenciones sucesivas (Ej.: para modificar el código debido a un cambio de alquiler).

El instalador y/o el presidente de comunidad deberán guardar la lista así rellena, junto con la tarjeta de backup.

LISTA NUMERICA TRASMETTITORI - NUMERICAL TRANSMITTER LIST - LISTE NUMÉRIQUE DES ÉMETTEURS - NUMERISCHES VERZEICHNIS DER SENDER - LISTA NUMÉRICA TRANSMISORES

 1 item	 27 item	 53 item	 79 item	 105 item
 2 item	 28 item	 54 item	 80 item	 106 item
 3 item	 29 item	 55 item	 81 item	 107 item
 4 item	 30 item	 56 item	 82 item	 108 item
 5 item	 31 item	 57 item	 83 item	 109 item
 6 item	 32 item	 58 item	 84 item	 110 item
 7 item	 33 item	 59 item	 85 item	 111 item
 8 item	 34 item	 60 item	 86 item	 112 item
 9 item	 35 item	 61 item	 87 item	 113 item
 10 item	 36 item	 62 item	 88 item	 114 item
 11 item	 37 item	 63 item	 89 item	 115 item
 12 item	 38 item	 64 item	 90 item	 116 item
 13 item	 39 item	 65 item	 91 item	 117 item
 14 item	 40 item	 66 item	 92 item	 118 item
 15 item	 41 item	 67 item	 93 item	 119 item
 16 item	 42 item	 68 item	 94 item	 120 item
 17 item	 43 item	 69 item	 95 item	 121 item
 18 item	 44 item	 70 item	 96 item	 122 item
 19 item	 45 item	 71 item	 97 item	 123 item
 20 item	 46 item	 72 item	 98 item	 124 item
 21 item	 47 item	 73 item	 99 item	 125 item
 22 item	 48 item	 74 item	 100 item	 126 item
 23 item	 49 item	 75 item	 101 item	 127 item
 24 item	 50 item	 76 item	 102 item	 128 item
 25 item	 51 item	 77 item	 103 item	
 26 item	 52 item	 78 item	 104 item	

ITALIANO

Per tutte le operazioni di selezione dip, è necessario **tenere ben ferma la scheda con una mano** e con l'altra spostare i dip con un piccolo cacciavite.

⚠ ATTENZIONE! Prima di ogni operazione di **connessione o sconnessione** delle schede, bisogna **togliere la tensione di linea all'impianto.**

ENGLISH

When performing any of the dip-switch selection operations, **the board must be held firmly by one hand** whilst the other moves the dip-switches with the aid of a small screwdriver.

⚠ CAUTION! Before doing any **connection or disconnection** work on the board, **the system must be disconnected from the power supply.**

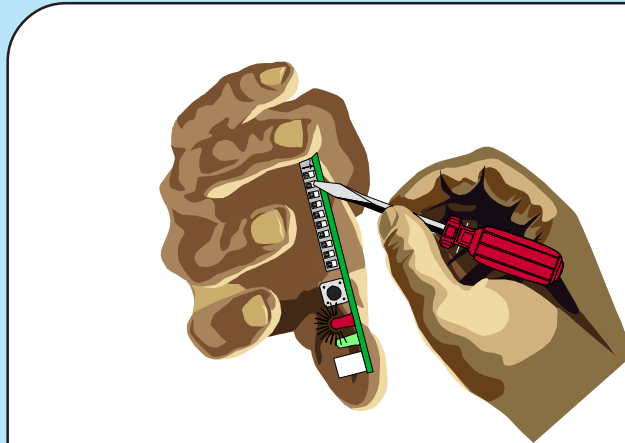

FRANCAIS

Pour toutes les opérations de sélection des dips, **bien tenir la carte d'une main** et déplacer les dips de l'autre à l'aide d'un petit tournevis.

⚠ ATTENTION! Avant de **brancher ou de débrancher** les cartes, **couper le courant de l'installation.**

DEUTSCH

Wenn die Stellung der Dip-Wählschalter verändert werden soll, bitte **die Karte mit einer Hand gut festhalten** und den Dip-Schalter mit der anderen Hand mithilfe eines kleinen Schraubenziehers verschieben.

⚠ ACHTUNG! Jedesmal, wenn die Karten **angeschlossen oder ausgebaut** werden, **muß der Strom an der Anlage abgeschaltet** werden.

ESPAÑOL

Para todas las operaciones de selección en los dip, es necesario **sujetar firmemente la tarjeta con una mano** y con la otra desplazar los dip con la ayuda de un pequeño destornillador.

⚠ ¡ATENCIÓN! Antes de cualquier operación de **conexión o desconexión** de las tarjetas hay que **quitar la tensión de línea a la instalación.**

C

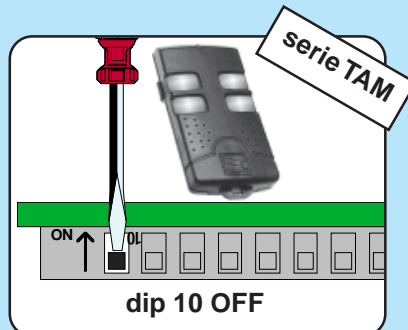
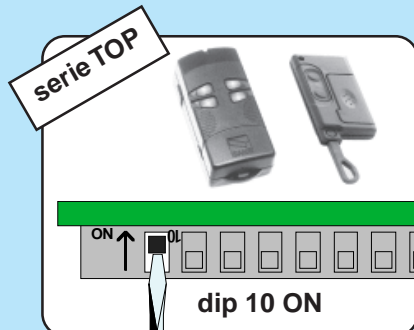
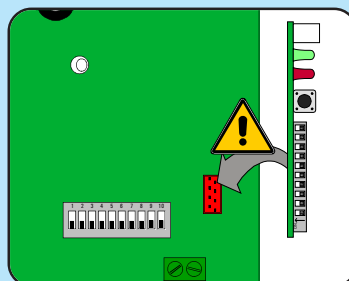
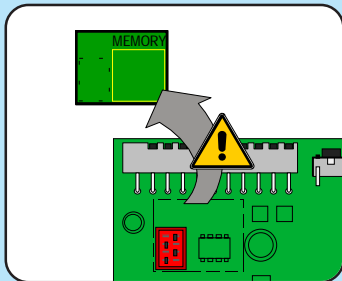

ITALIANO

Togliere la schedina di Backup. Inserire la scheda AF43sM sull'apposita scheda/ricevitore dell'automazione comune (quella che deve essere comandata da tutti gli utenti).

Procedere con la selezione sul dip 10 per scegliere l'abbinamento con i trasmettitori.

ENGLISH

Remove the backup board. Insert the AF43sM board on the relevant board/receiver of the communal automated device (the one which must be controlled by all the users). Proceed to move dip-switch 10 in order to set up the association with the transmitters.

FRANCAIS

Enlever la carte de sauvegarde. Placer la carte AF43sM sur la carte/récepteur correspondante de la motorisation en commun (celle qui doit être commandée par tous les utilisateurs).

Effectuer la sélection sur le dip 10 pour choisir l'accouplement avec les émetteurs

DEUTSCH

Entfernen Sie die Backup-Karte. Stecken Sie die Karte AF43sM in den entsprechenden Steckplatz/Empfänger der gemeinsamen Automatiksteuerung (die von allen Benutzern gemeinsam bedient wird).

Wählen Sie mithilfe vom Dip-Schalter 10 die Kombination mit den Sendern aus.

ESPAÑOL

Quitar la tarjeta de Backup. Introducir la tarjeta AF43sM en la tarjeta/receptor de la automatización común (aquella que tiene que ser mandada por todos los usuarios). Realizar la selección en el dip 10 para elegir la asociación con los transmisores.

ITALIANO

E' consigliabile, **prima di procedere**, fare una **cancellazione totale della memoria** (vedi pag. 10), per assicurarsi che non esistano codici lasciati dai test di collaudo.

C - REGISTRAZIONE CODICI

- 1 Posizionare:
 - a) il dip 9 in ON per il canale CH1
 - b) i dip 8 e 9 in ON per il canale CH2
 - 1.1 Si accende il led verde
- 2 Inviare il codice con il trasmettitore
 - 2.1 Lampeggia il led rosso per 3"
 - 2.2 Alla riaccensione del led verde, l'operazione è terminata

Ripetere queste operazioni per tutti i trasmettitori (**uno** per ogni numero della distinta codici) presenti nell'impianto

ENGLISH

Before proceeding to erase the memory completely (see page 10), it is advisable to make sure that no codes have been left behind from the inspection tests.

C - RECORDING CODES

- 1 Set:
 - dip-switch 9 to ON for the CH1 channel
 - dip-switch 8 and 9 to ON for the CH2 channel
 - 1.1 The green LED comes on
- 2 Send the code using the transmitter
 - 2.1 The red LED flashes for 3"
 - 2.2 Once the green LED comes back on, the operation is concluded.

Repeat the procedure above for all the transmitters (**one** for each number on the code list) in the system.

DEUTSCH

Bevor Sie **mit der Eingabe der Codes beginnen**, ist es ratsam, **den gesamten Speicher zu löschen** (siehe S. 10), um sicherzugehen, daß keine Codes vorhanden sind, die im Rahmen der Abnahmeprüfung eingegeben wurden.

C - EINGABE DER CODES

- 1 Stellen Sie:
 - den Dip 9 auf ON für den Kanal CH1;
 - die Dip 8 und 9 auf ON für den Kanal CH2.
 - 1.1 Die grüne Kontrollleuchte geht an.
- 2 Übertragen Sie den Code mit dem Sender.
 - 2.1 Die rote Kontrollleuchte blinkt 3 s lang.
 - 2.2 Wenn die grüne Kontrollleuchte wieder angeht, ist der Arbeitsschritt abgeschlossen.

Wiederholen Sie diesen Arbeitsschritt für alle Sender (**einen** für jede Nummer vom Verzeichnis der Codes) der Anlage.

FRANCAIS

Avant de continuer, il est conseillé **d'annuler entièrement la mémoire** (voir page 10), pour être sûrs qu'il n'y ait plus de codes suite aux tests de fonctionnement.

C - ENREGISTREMENT DES CODES

- 1 Mettre:
 - le dip 9 sur ON pour le canal CH1
 - les dips 8 et 9 sur ON pour le canal CH2
 - 1.1 Le led vert s'allume
- 2 Saisir le code ainsi que l'émetteur
 - 2.1 Le led rouge clignote pendant 3"
 - 2.2 L'opération est terminée quand le led vert se rallume

Répéter ces opérations pour tous les émetteurs (**un** pour chaque numéro de la liste des codes) présents dans l'installation.

ESPAÑOL

Es recomendable, **antes de empezar las operaciones**, realizar un **borrado total de la memoria** (ver pág. 10), para asegurarse de que no hayan quedado códigos de los controles realizados en las pruebas.

C - REGISTRO DE CÓDIGOS

- 1 Posicionar:
 - el dip 9 en ON para el canal CH1
 - los dip 8 y 9 en ON para el canal CH2
 - 1.1 Se enciende el led verde
- 2 Enviar el código con el transmisor
 - 2.1 El led rojo parpadea por 3"
 - 2.2 Al encenderse de nuevo el led verde, la operación se ha terminado.

Repetir estas operaciones para todos los transmisores (**uno** por cada número de la lista de códigos) presentes en la instalación.

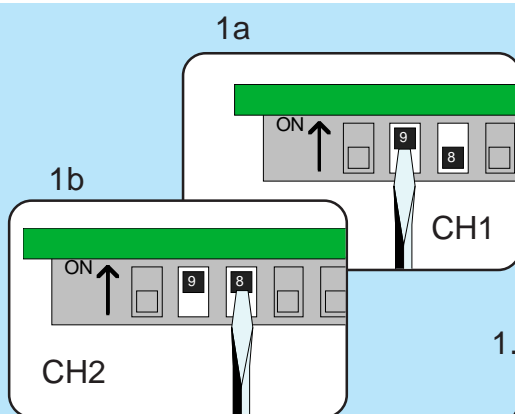

1.1

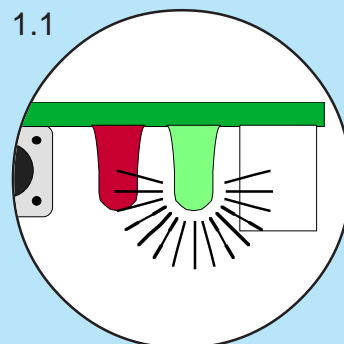

2

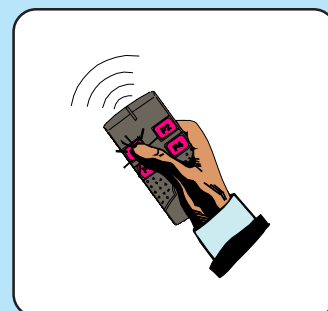

2.1

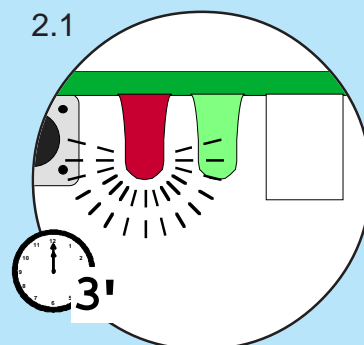

2.2

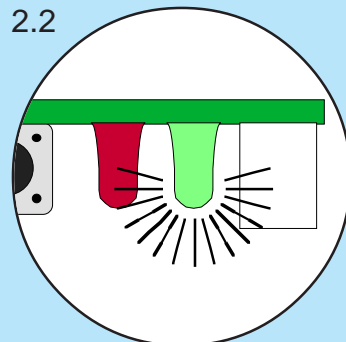

ITALIANO

D - COPIA SU RICEVITORE

- 1 Riportare i dip 8 e 9 in posizione OFF
- 2 Premere, **sulla scheda del ricevitore**, il pulsante CH dell'uscita prescelta
 - 2.1 Si accende il relativo led sul ricevitore
- 3 Con uno qualsiasi dei trasmettitori registrati in precedenza, inviare un impulso
 - 3.1 Un breve lampeggio del led rosso segnala l'avvenuta copia

N.B. Se nelle registrazioni di cui al punto C, i trasmettitori sono stati registrati parte su CH1 e parte su CH2, la procedura descritta va eseguita per entrambi i canali; l'invio dell'impulso va fatto con un trasmettitore del gruppo relativo

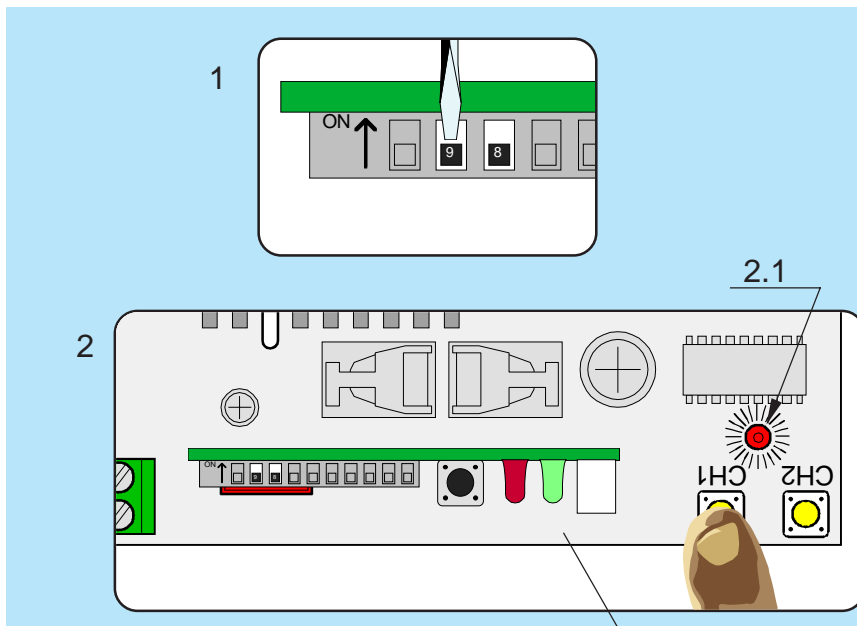

ENGLISH

D - COPY TO RECEIVER

- 1 Set dip-switches 8 and 9 to OFF again
- 2 Press the CH button of the chosen output **on the receiver's board**
 - 2.1 The relevant LED on the receiver comes on
- 3 Send a pulse using any of the previously recorded transmitters
 - 3.1 When the red LED flashes briefly, the copy has been made

N.B. In the event a number of the transmitters have been recorded, as mentioned under point C, on CH1 and the rest on CH2, the procedure described must be carried out for both channels; the pulse must be sent using a transmitter belonging to the relevant group

FRANCAIS

D - COPIE SUR RECEPTEUR

- 1 Remettre les dips 8 et 9 sur OFF
- 2 Appuyer sur le bouton CH de la sortie voulue sur la **carte du récepteur**
 - 2.1 Le led correspondant s'allume sur le récepteur
- 3 Envoyer une impulsion avec un des émetteurs enregistrés précédemment
 - 3.1 Le led rouge clignote brièvement pour signaler que la copie a été effectuée

N.B. Dans les enregistrements relatifs au point C, si les émetteurs ont été enregistrés en partie sur CH1 et en partie sur CH2, suivre la procédure décrite pour les deux canaux; l'impulsion doit être envoyée avec un émetteur du groupe correspondant

esempio
example
exemple **RBI 2**
Beispiel
ejemplo

3

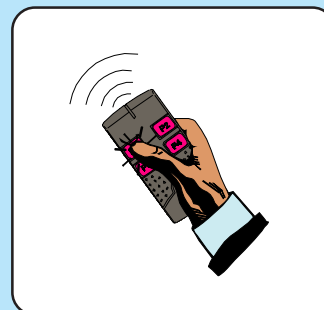

DEUTSCH

D - ÜBERTRAGEN AUF DEN EMPFÄNGER

- 1 Stellen Sie die Dip 8 und 9 wieder auf OFF.
- 2 Drücken Sie **auf der Empfängerkarte** den Knopf CH am gewählten Ausgang.
 - 2.1 Die entsprechende Kontrolleuchte am Empfänger geht an.
- 3 Übertragen Sie von einem der bereits registrierten Sender einen Impuls.
 - 3.1 Ein kurzes Blinken der roten Kontrolleuchte zeigt die erfolgreiche Übertragung an.

HINWEIS: Wenn bei der Eingabe der Codes (siehe Kap. C) ein Teil der Sender auf CH1 und ein Teil auf CH2 registriert worden sind, wird der oben beschriebenen Arbeitsschritt für beide Kanäle ausgeführt. Dabei erfolgt die Übertragung des Impulses mit einem Sender der entsprechenden Einheit.

ESPAÑOL

D - COPIA EN RECEPTOR

- 1 Poner de nuevo los dip 8 y 9 en OFF
- 2 Presionar, **en la tarjeta del receptor**, el botón CH relativo a la salida elegida
 - 2.1 Se enciende el led relativo en el receptor
- 3 Con uno cualquiera de los transmisores registrados con anterioridad, enviar un impulso
 - 3.1 Un breve parpadeo del led rojo señala que se ha realizado la copia.

NOTA Si en los registros mencionados en el punto C, una parte de los transmisores se ha registrado en CH1 y otra parte en CH2, el procedimiento descrito se tiene que llevar a cabo para ambos canales; el envío del impulso se tiene que realizar con un transmisor del grupo correspondiente

3.1

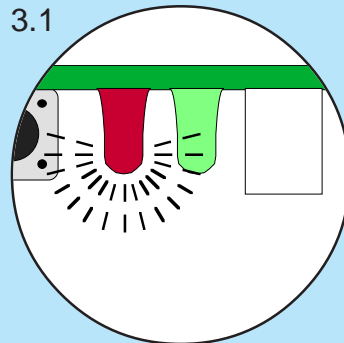

ITALIANO

MAN1 - CANCELLAZIONE SINGOLO CODICE

- 1 Selezionare sui dip 1÷7 la combinazione del codice così come risulta dalla lista numerica dei trasmettitori (nell'esempio la n° 5 della lista)
- 2 Premere, senza rilasciarlo, il pulsante di attivazione delle funzioni
 - 2.1 Si accende il led rosso per 5"
 - 2.2 All'accensione del led verde, l'operazione è terminata
- 3 Rilasciare il pulsante di attivazione delle funzioni (**N.B. se non si rilascia il pulsante entro 5", viene eseguita la procedura di cancellazione totale di cui al punto MAN2**)

Ripetere queste operazioni per tutti i trasmettitori che si vuole cancellare

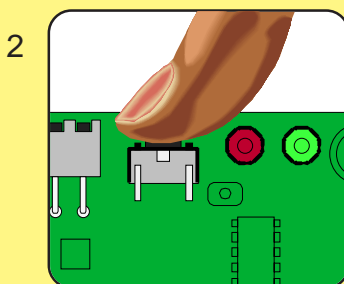
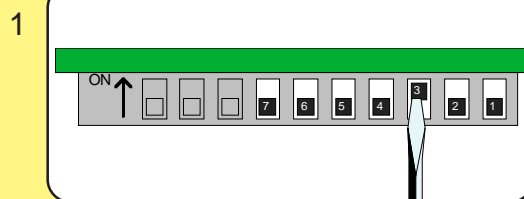

ENGLISH

MAN1 - DELETING INDIVIDUAL CODES

- 1 Select the code combination, as featured on the numerical transmitter list, on dip-switches 1÷7 (in the example, n° 5 on the list)
- 2 Press the function enabling button and do not release
 - 2.1 The red LED comes on for 5"
 - 2.2 Once the green LED comes on, the operation is concluded
- 3 Release the function enabling button (**N.B. if the button is not released before the 5" are up, the total erasure procedure is performed, as mentioned under point MAN2**)

Repeat this procedure for all the transmitters to be deleted

FRANCAIS

MAN1 - ANNULATION D'UN CODE

- 1 Sur les dips 1÷7, sélectionner la combinaison du code comme indiquée sur la liste numérique des émetteurs (dans l'exemple, la combinaison 5 de la liste)
- 2 Appuyer, sans le relâcher, sur le bouton d'activation des fonctions
 - 2.1 Le led rouge s'allume pendant 5"
 - 2.2 L'opération est terminée quand le led vert s'allume
- 3 Relâcher le bouton d'activation des fonctions (**N.B. si on ne relâche pas ce bouton au bout de 5", la procédure d'annulation totale relative au point ENT2 est effectuée**)

Répéter ces opérations pour tous les émetteurs que l'on veut annuler

DEUTSCH

MAN1 - LÖSCHEN EINZELNER CODES

- 1 Stellen Sie an den Dip-Schaltern 1 bis 7 die Codekombination so ein, wie aus dem numerischen Verzeichnis der Sender hervorgeht (z.B. die Nr. 5 des Verzeichnisses).
- 2 Drücken Sie den Startknopf für die Funktionen und halten Sie ihn gedrückt.
 - 2.1 Die rote Kontrollleuchte leuchtet 5 s lang auf.
 - 2.2 Wenn die grüne Kontrollleuchte angeht, ist der Arbeitsschritt abgeschlossen.
- 3 Lassen Sie den Startknopf der Funktionen wieder los. (**HINWEIS: Wenn Sie den Knopf nicht innerhalb von 5 s loslassen, wird der gesamte Speicher gelöscht - siehe Punkt W2**).

Wiederholen Sie diesen Arbeitsschritt für alle Sender, die gelöscht werden sollen.

ESPAÑOL

MAN1 - BORRADO DE CÓDIGOS POR SEPARADO

- 1 Seleccionar en los dip 1÷7 la asociación del código tal y como resulta en la lista numérica de los transmisores (en el ejemplo la n° 5 de la lista)
- 2 Oprimir sin soltarlo el botón de activación de las funciones
 - 2.1 El led rojo se enciende por 5"
 - 2.2 Al encenderse el led verde, la operación se ha terminado.
- 3 Soltar el botón de activación de las funciones (**NOTA si no se suelta el botón dentro de 5", se ejecuta el procedimiento de borrado total indicado en el punto MAN2**)

Repetir estas operaciones para todos los transmisores que se desea borrar

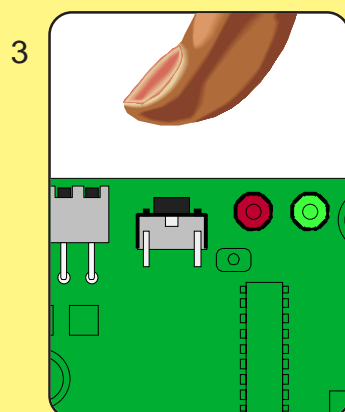
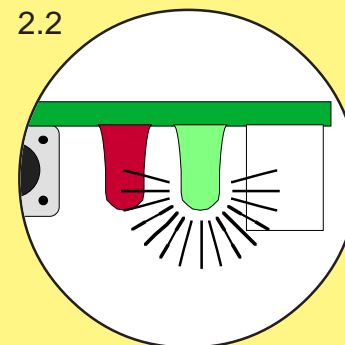
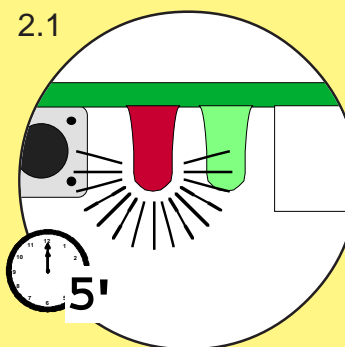

MAN2

ITALIANO

MAN2 - CANCELLAZIONE INTERA MEMORIA

- 1 Premere, senza rilasciarlo, il pulsante di attivazione delle funzioni
 - 1.1 Si accende il led rosso per 5"
 - 1.2 Si accende il led verde per 5"
 - 1.3 Lampeggia il led rosso per 3"
 - 1.4 Alla riaccensione del led verde, l'operazione è terminata
- 2 Rilasciare il pulsante di attivazione delle funzioni

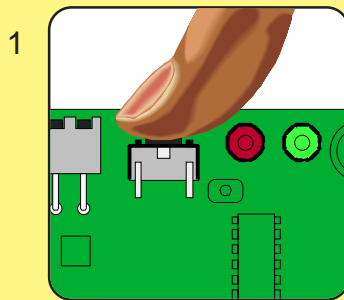

ENGLISH

MAN2 - ERASING THE WHOLE MEMORY

- 1 Press the function enabling button and do not release
 - 1.1 The red LED comes on for 5"
 - 1.2 The green LED comes on for 5"
 - 1.3 The red LED flashes for 3"
 - 1.4 Once the green LED comes back on, the operation is concluded
- 2 Release the function enabling button

1.2

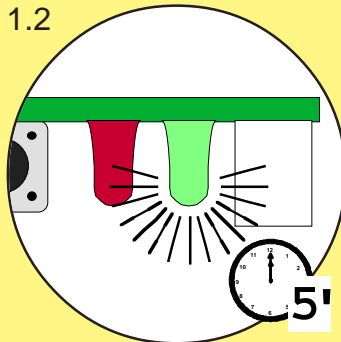

1.1

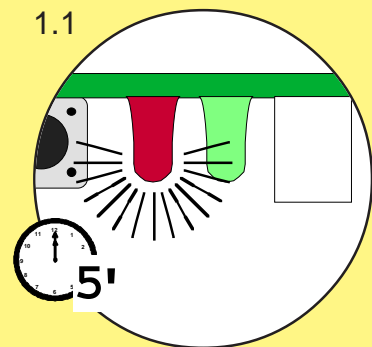

1.3

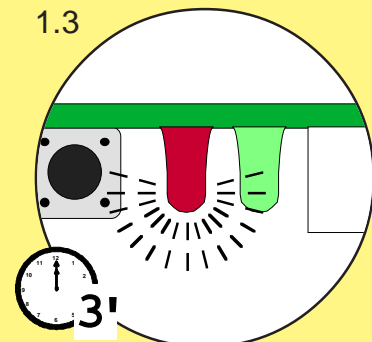

1.4

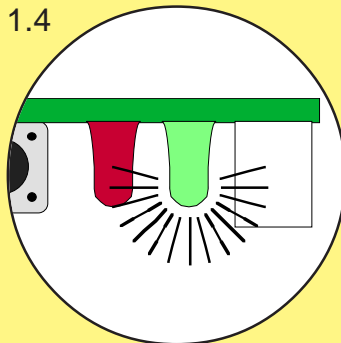

FRANCAIS

MAN2 - ANNULATION DE TOUTE LA MÉMOIRE

- 1 Appuyer, sans le relâcher, sur le bouton d'activation des fonctions
 - 1.1 Le led rouge s'allume pendant 5"
 - 1.2 Le led vert s'allume pendant 5"
 - 1.3 Le led rouge clignote pendant 3"
 - 1.4 L'opération est terminée quand le led vert se rallume
- 2 Relâcher le bouton d'activation des fonctions

DEUTSCH

MAN2 - LÖSCHEN DES GESAMTEN SPEICHERS

- 1 Drücken Sie den Startknopf der Funktionen und halten Sie ihn gedrückt.
 - 1.1 Die rote Kontrolleuchte leuchtet 5 s lang auf.
 - 1.2 Die grüne Kontrolleuchte leuchtet 5 s lang auf.
 - 1.3 Die rote Kontrolleuchte blinkt 3 s lang.
 - 1.4 Wenn die grüne Kontrolleuchte wieder angeht, ist der Arbeitsschritt abgeschlossen.
- 2 Lassen Sie den Startknopf der Funktionen wieder los.

ESPAÑOL

MAN2 - BORRADO TOTAL DE LA MEMORIA

- 1 Oprimir sin soltarlo el botón de activación de las funciones
 - 1.1 El led rojo se enciende por 5"
 - 1.2 El led verde se enciende por 5"
 - 1.3 El led rojo parpadea por 3"
 - 1.4 Al encenderse de nuevo el led verde, la operación se ha terminado
- 2 Soltar el botón de activación de las funciones

2

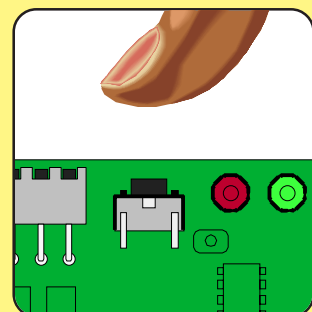

MAN3

ITALIANO

MAN3 - AGGIUNTA CODICI

Ripetere le procedure A B C e D precedentemente descritte.

In breve:

- codificare i trasmettitori
- aggiungerli alla lista (in sequenza)
- registrarli sul canale voluto
- copiarli sul ricevitore

Verranno automaticamente memorizzati a partire dalla prima posizione libera

ENGLISH

MAN3 - ADDING CODES

Repeat the procedures A B C and D described above.

To sum up:

- code the transmitters
- add them to the list (in order)
- record them on the chosen channel
- copy them onto the receiver

They will be saved automatically as from the first free position

FRANCAIS

MAN3 - ADJONCTION DE CODES

Répéter les procédures A B C et D décrites précédemment.

C'est-à-dire:

- codifier les émetteurs
- les ajouter à la liste (en séquence)
- les enregistrer sur le canal voulu
- les copier sur le récepteur

Les codes seront mémorisés automatiquement à partir de la première position libre

DEUTSCH

MAN3 - ERGÄNZUNG VON CODES

Wiederholen Sie die unter A, B, C und D beschriebenen Arbeitsschritte.

kurz gesagt:

- kodieren Sie die Sender;
- fügen Sie sie in das Verzeichnis ein (in Reihenfolge);
- registrieren Sie sie auf dem gewünschten Kanal;
- übertragen Sie sie an den Empfänger;

Die Codes werden automatisch ab der ersten freien Position gespeichert.

ESPAÑOL

MAN3 - AÑADIDO DE CÓDIGOS

Repetir los procedimientos A B C y D descritos con anterioridad.

En resumen:

- codificar los transmisores
- añadirlos a la lista (en secuencia)
- registrarlos en el canal deseado
- copiarlos en el receptor

Se almacenarán de modo automático a partir de la primera posición libre.

MAN4

ITALIANO

MAN4 - MODIFICA CODICI

Bisogna prima cancellare il codice che si vuole modificare (proc. MAN1).

Ripetere quindi le procedure A B C e D come per AGGIUNTA CODICI.

Verrà automaticamente memorizzato nella posizione liberata dalla cancellazione.

N.B. Se si devono cambiare più codici, è consigliabile modificarli uno alla volta.

ENGLISH

MAN4 - EDITING CODES

The code to be edited must first be deleted (proc. MAN1).

Consequently, repeat procedures A B C and D as described for ADDING CODES.

It will automatically be saved in the position left free by the deleted code.

N.B. If a number of codes are to be edited, it is advisable to do one at a time.

FRANCAIS

MAN4 - MODIFICATION DES CODES

Il faut d'abord annuler le code que l'on veut modifier (procéd. MAN1).

Répéter ensuite les procédures A B C et D comme pour l'ADJONCTION DE CODES.

Le code sera mémorisé automatiquement à la place du code qui vient d'être annulé.

N.B. Il est conseillé de modifier un code à la fois s'il y en a plusieurs à modifier.

DEUTSCH

MAN4 - VERÄNDERUNG DER CODES

Dazu muß zunächst der Code, der verändert werden soll, gelöscht werden (siehe Punkt W1).

Wiederholen Sie dann die Arbeitsschritte A, B, C, und D wie oben unter Punkt „Ergänzung von Codes“ beschrieben.

Der Code wird automatisch in der Position abgespeichert, die durch das Löschen frei geworden ist.

HINWEIS: Wenn mehrere Codes verändert werden müssen, verändern Sie die Codes am besten einzeln nacheinander.

ESPAÑOL

MAN4 - MODIFICACIÓN DE CÓDIGOS

Primero hay que borrar el código que se desea modificar (proc. MAN1).

Luego repetir los procedimientos A B C y D como para la operación de AÑADIDO DE CÓDIGOS.

Se almacenará de modo automático en la posición que ha quedado libre tras el borrado.

NOTA Si se tienen que modificar varios códigos, es aconsejable hacerlo con cada uno por separado.

ITALIANO

MAN5 - RECUPERO SINGOLI CODICI

- 1 Posizionare il dip 8 in ON
- 2 Selezionare sui dip 1÷7 la combinazione del codice così come risulta dalla lista numerica dei trasmettitori (nell'esempio il n° 5 della lista)
- 3 Premere, senza rilasciarlo, il pulsante di attivazione delle funzioni
 - 3.1 Si accende il led verde per 5"
 - 3.2 All'accensione del led rosso, l'operazione è terminata
- 4 Rilasciare il pulsante di attivazione delle funzioni (**N.B.** se non si rilascia il pulsante entro 5", viene eseguita la procedura di recupero totale di cui al punto MAN6)

Ripetere queste operazioni per tutti i trasmettitori che si vogliono recuperare

1

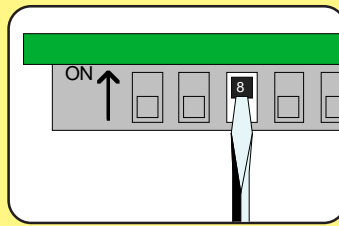

2

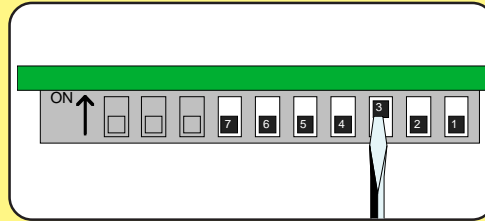

3

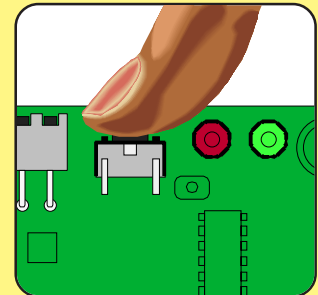

3.1

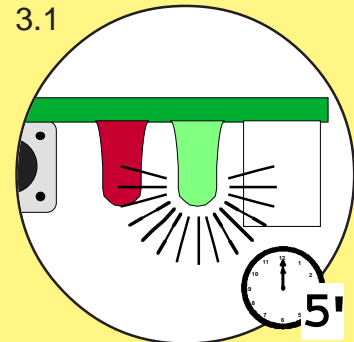

3.2

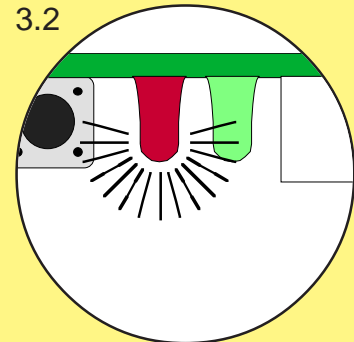

4

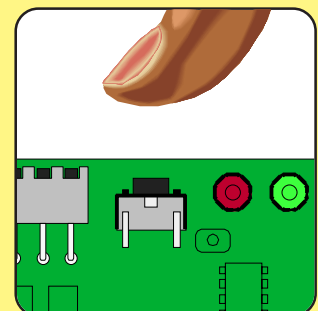

ENGLISH

MAN5 - RESTORING INDIVIDUAL CODES

- 1 Set dip-switch 8 to ON
- 2 Select the code combination, as featured on the numerical transmitter list, on dip-switches 1÷7 (in the example, n° 5 on the list)
- 3 Press the function enabling button and do not release
 - 3.1 The green LED comes on for 5"
 - 3.2 Once the red LED comes on, the operation is concluded
- 4 Release the function enabling button (**N.B.** if the button is not released before the 5" are up, the total restore procedure is performed, as mentioned under point MAN6)

Repeat this procedure for all the transmitters to be restored

FRANCAIS

MAN5 - RECUPERATION DES DIFFÉRENTS CODES

- 1 Mettre le dip 8 sur ON
- 2 Sur les dips 1÷7, sélectionner la combinaison du code comme indiquée sur la liste numérique des émetteurs (dans l'exemple, la combinaison 5 de la liste)
- 3 Appuyer, sans le relâcher, sur le bouton d'activation des fonctions
 - 3.1 Le led vert s'allume pendant 5"
 - 3.2 L'opération est terminée quand le led rouge s'allume
- 4 Relâcher le bouton d'activation des fonctions (**N.B.** si on ne relâche pas ce bouton au bout de 5", la procédure de récupération totale relative au point ENT6 est effectuée)

Répéter ces opérations pour tous les émetteurs que l'on veut récupérer

DEUTSCH

MAN5 - RETTEN EINZELNER CODES

- 1 Stellen Sie den Dip 8 auf ON.
- 2 Stellen Sie an den Dip-Schaltern 1 bis 7 die Codekombination so ein, wie aus dem numerischen Verzeichnis der Sender hervorgeht (z.B. die Nr. 5 des Verzeichnisses).
- 3 Drücken Sie den Startknopf der Funktionen und halten Sie ihn gedrückt.
 - 3.1 Die grüne Kontrollleuchte leuchtet 5 s lang auf.
 - 3.2 Wenn die rote Kontrollleuchte angeht, ist der Arbeitsschritt abgeschlossen.
- 4 Lassen Sie den Startknopf der Funktionen wieder los. (**HINWEIS:** Wenn Sie den Knopf nicht innerhalb von 5 s loslassen, wird der gesamte Speicher gerettet - siehe Punkt MAN6).

Wiederholen Sie diesen Arbeitsschritt für alle Sender, die gerettet werden sollen.

ESPAÑOL

MAN5 - RECUPERACIÓN DE CÓDIGOS POR SEPARADO

- 1 Posicionar el dip 8 en ON
- 2 Seleccionar en los dip 1÷7 la asociación del código tal y como resulta en la lista numérica de los transmisores (en el ejemplo el n° 5 de la lista)
- 3 Oprimir sin soltarlo el botón de activación de las funciones
 - 3.1 El led verde se enciende por 5"
 - 3.2 Al encenderse el led rojo, la operación se ha terminado
- 4 Soltar el botón de activación de las funciones (**NOTA** si no se suelta el botón dentro de 5", se ejecuta el procedimiento de recuperación total indicado en el punto MAN6)

Repetir estas operaciones para todos los transmisores que se desea recuperar

ITALIANO

MAN6 - RECUPERO INTERA MEMORIA

- 1 Posizionare il dip 8 in ON
- 2 Premere, senza rilasciarlo, il pulsante di attivazione delle funzioni
 - 2.1 Si accende il led verde per 5"
 - 2.2 Si accende il led rosso per 5"
 - 2.3 Lampeggia il led rosso per 1"
 - 2.4 Quando rimane acceso il led rosso, l'operazione è terminata
- 3 Rilasciare il pulsante di attivazione delle funzioni

ENGLISH

MAN6 - RESTORING THE WHOLE MEMORY

- 1 Set dip-switch 8 to ON
- 2 Press the function enabling button and do not release
 - 2.1 The green LED comes on for 5"
 - 2.2 The red LED comes on for 5"
 - 2.3 The red LED flashes for 1"
 - 2.4 Once the red LED remains lit, the operation is concluded
- 3 Release the function enabling button

FRANCAIS

MAN6 - RECUPERATION DE TOUTE LA MEMOIRE

- 1 Mettre le dip 8 sur ON
- 2 Appuyer, sans le relâcher, sur le bouton d'activation des fonctions
 - 2.1 Le led vert s'allume pendant 5"
 - 2.2 Le led rouge s'allume pendant 5"
 - 2.3 Le led rouge s'allume pendant 1"
 - 2.4 L'opération est terminée quand le led rouge reste allumé
- 3 Relâcher le bouton d'activation des fonctions

DEUTSCH

MAN6 - RETTEN DES GESAMTEN SPEICHERS

- 1 Stellen Sie den Dip 8 auf ON.
- 2 Drücken Sie den Startknopf der Funktionen und halten Sie ihn gedrückt.
 - 2.1 Die grüne Kontrollleuchte leuchtet 5 s lang auf.
 - 2.2 Die rote Kontrollleuchte leuchtet 5 s lang auf.
 - 2.3 Die rote Kontrollleuchte blinkt 1 s lang.
 - 2.4 Wenn die rote Kontrollleuchte angeht, ist der Arbeitsschritt abgeschlossen.
- 3 Lassen Sie den Startknopf der Funktionen wieder los.

ESPAÑOL

MAN6 - RECUPERACIÓN TOTAL DE LA MEMORIA

- 1 Posicionar el dip 8 en ON
- 2 Oprimir sin soltarlo el botón de activación de las funciones
 - 2.1 El led verde se enciende por 5"
 - 2.2 El led rojo se enciende por 5"
 - 2.3 El led rojo parpadea por 1"
 - 2.4 Cuando el led rojo permanece encendido, la operación se ha terminado.
- 3 Soltar el botón de activación de las funciones

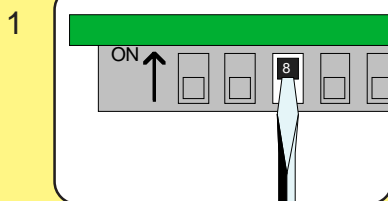

2

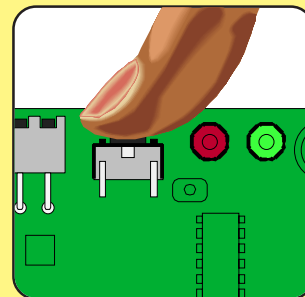

2.1

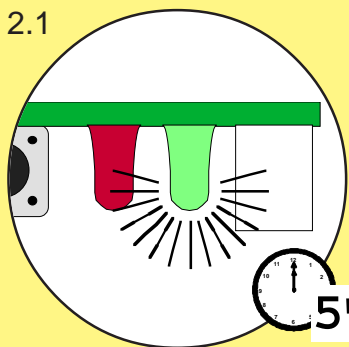

2.2

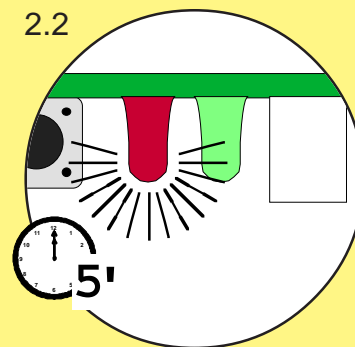

2.3

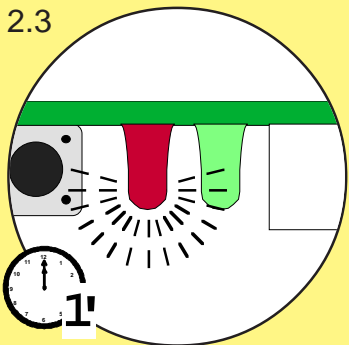

2.4

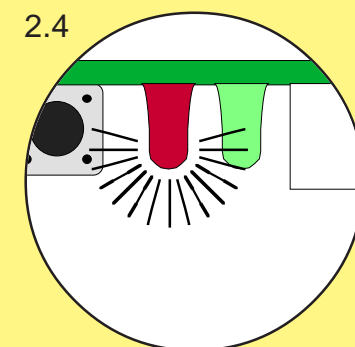

3

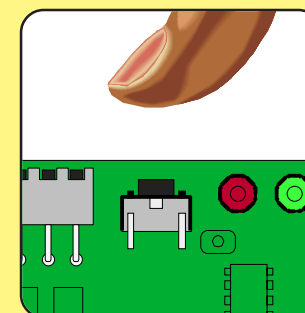

ITALIANO

MAN7 - COPIA DI BACKUP

- 1* Inserire la schedina di backup "MEMORY" sull'apposito innesto
- 2 Posizionare il dip 9 in ON
 - 2.1 Lampeggiano entrambi i led per 10"
 - 2.2 Rimane acceso il led verde
 - 2.3 Dopo 3" rimangono accesi entrambi e l'operazione è terminata
- 3 Riportare il dip 9 in OFF
- 4* Togliere la schedina di backup e archivarla con la distinta codici

! * **ATTENZIONE!** Prima di ogni operazione di **connessione o sconnessione**, **togliere la tensione di linea all'impianto.**

ENGLISH

MAN7 - BACKUP COPY

- 1* Insert the backup "MEMORY" board in the relevant slot
- 2 Set dip-switch 9 to ON
 - 2.1 Both LEDs flash for 10"
 - 2.2 The green LED remains lit
 - 2.3 After 3" both remain lit and the operation is concluded
- 3 Set dip-switch 9 back to OFF
- 4* Remove the backup board and store it in a safe place with the code list

! * **CAUTION!** Before doing any **connection or disconnection work**, the **system must be disconnected from the power supply.**

FRANCAIS

MAN7 - COPIE DE SAUVEGARDE

- 1* Placer la carte de sauvegarde "MEMORY" sur la connexion correspondante
- 2 Mettre le dip 9 sur ON
 - 2.1 Les deux leds clignotent pendant 10"
 - 2.2 Le led vert reste allumé
 - 2.3 Les deux leds restent allumés au bout de 3", l'opération est alors terminée
- 3 Remettre le dip 9 sur OFF
- 4* Enlever la carte de sauvegarde et la ranger avec la liste des codes

! * **ATTENTION!** Avant de **brancher ou de débrancher** les cartes, **couper le courant de l'installation.**

DEUTSCH

MAN7 - BACKUP SICHERUNGSKOPIE

- 1* Stecken Sie die Backup-Karte „MEMORY“ in den entsprechenden Steckplatz.
- 2 Stellen Sie den Dip 9 auf ON.
 - 2.1 Beide Kontrolleuchten blinken 10 s lang.
 - 2.2 Die grüne Kontrolleuchte geht an
 - 2.3 Nach 3 s geht auch die zweite Kontrolleuchte an und der Arbeitsschritt ist abgeschlossen.
- 3 Stellen Sie den Dip 9 wieder auf OFF
- 4* Nehmen Sie die Backup-Karte aus dem Steckplatz und legen Sie sie zusammen mit dem Verzeichnis der Codes ab.

! * **ACHTUNG!** Jedesmal, wenn die Karte **angeschlossen oder ausgebaut wird**, **muß der Strom an der Anlage abgeschaltet werden.**

ESPAÑOL

MAN7 - COPIA DE SEGURIDAD (BACKUP)

- 1* Introducir la tarjeta de backup "MEMORY" en el acoplamiento presente a tal efecto
- 2 Situar el dip 9 en ON
 - 2.1 Ambos led parpadean por 10"
 - 2.2 Permanece encendido el led verde
 - 2.3 Al cabo de 3" permanecen encendidos ambos led y la operación se ha terminado
- 3 Poner el dip 9 en OFF
- 4* Quitar la tarjeta de backup y archivarla con la lista de códigos

! * **¡ATENCIÓN!** Antes de cualquier operación de **conexión o desconexión** hay que **quitar la tensión de línea a la instalación.**

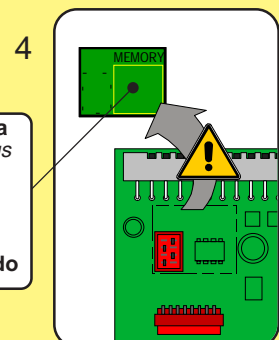
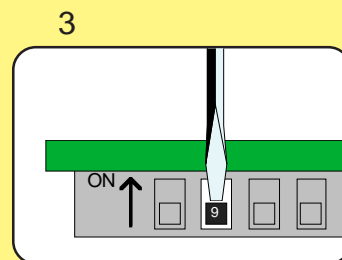
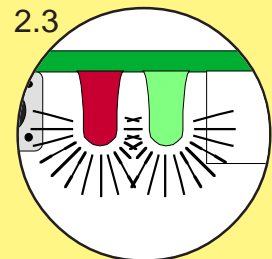
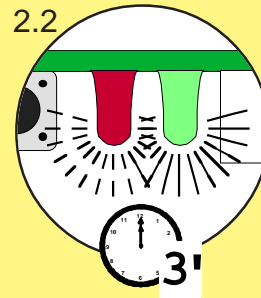
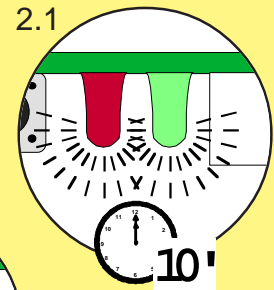
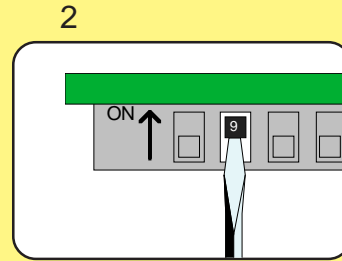
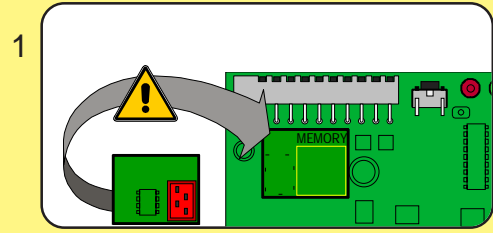

spazio per marcatura
space for markings
espace réservé au
marquage
Raum für
Kennzeichnung
espacio para marcado

ITALIANO

MAN8 - RESTORE MEMORIA

- 1* Inserire la schedina di backup "MEMORY" sull'apposito innesto
- 2 Premere, senza rilasciarlo, il pulsante di attivazione delle funzioni
 - 2.1 Lampeggiano entrambi i led per 10"
 - 2.2 Rimane acceso il led rosso
 - 2.3 Dopo 3" rimangono accesi entrambi e l'operazione è terminata
- 3 Rilasciare il pulsante di attivazione delle funzioni
- 4* Togliere la schedina di backup e archivarla con la distinta codici

⚠ * **ATTENZIONE!** Prima di ogni operazione di **connessione o sconnessione**, togliere la tensione di linea all'impianto.

ENGLISH

MAN8 - REINSTALL MEMORY

- 1* Insert the backup "MEMORY" board in the relevant slot
- 2 Press the function enabling button and do not release
 - 2.1 Both LEDs flash for 10"
 - 2.2 The red LED remains lit
 - 2.3 After 3" both remain lit and the operation is concluded
- 3 Release the function enabling button
- 4* Remove the backup board and store it in a safe place with the code list

⚠ * **CAUTION!** Before doing any **connection or disconnection work**, the system must be disconnected from the power supply.

FRANCAIS

MAN8 - REPRIS DE LA MEMOIRE

- 1* Placer la carte de sauvegarde "MEMORY" sur la connexion correspondante
- 2 Appuyer, sans le relâcher, sur le bouton d'activation des fonctions
 - 2.1 Les leds clignotent pendant 10"
 - 2.2 Le led rouge reste allumé
 - 2.3 Les deux leds restent allumés au bout de 3", l'opération est alors terminée
- 3 Relâcher le bouton d'activation des fonctions
- 4* Enlever la carte de sauvegarde et la ranger avec la liste des codes

⚠ **ATTENTION!** Avant de **brancher ou de débrancher les cartes**, couper le courant de l'installation.

DEUTSCH

MAN8 - RESTORE DER CODES

- 1* Stecken Sie die Backup-Karte „MEMORY“ in den entsprechenden Steckplatz.
- 2 Drücken Sie den Startknopf der Funktionen und halten Sie ihn gedrückt.
 - 2.1 Die Kontrolleuchten blinken 10 s lang.
 - 2.2 Die rote Kontrolleuchte geht an.
 - 2.3 Nach 3 s geht auch die grüne Kontrolleuchte an und der Arbeitsschritt ist abgeschlossen.
- 3 Lassen Sie den Startknopf der Funktionen wieder los.
- 4* Nehmen Sie die Backup-Karte aus dem Steckplatz und legen Sie sie zusammen mit dem Verzeichnis der Codes ab.

⚠ * **ACHTUNG!** Jedesmal, wenn die Karte **angeschlossen oder ausgebaut wird**, muß der Strom an der Anlage abgeschaltet werden

ESPAÑOL

MAN8 - RESTAURACIÓN MEMORIA (RESTORE)

- 1* Introducir la tarjeta de backup "MEMORY" en el acoplamiento previsto
- 2 Oprimir sin soltarlo el botón de activación de las funciones
 - 2.1 Los led parpadean por 10"
 - 2.2 El led rojo permanece encendido
 - 2.3 Al cabo de 3" ambos led permanecen encendidos y la operación se ha terminado
- 3 Soltar el botón de activación de las funciones
- 4* Quitar la tarjeta de backup y archivarla con la lista de códigos

⚠ * **¡ATENCIÓN!** Antes de cualquier operación de **conexión o desconexión** hay que quitar la tensión de línea a la instalación.

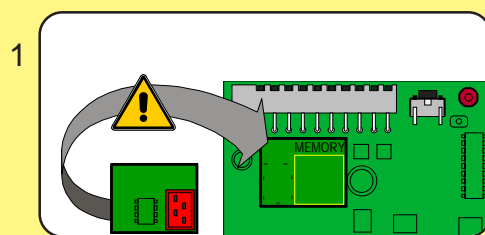

2

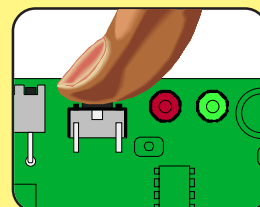

2.1

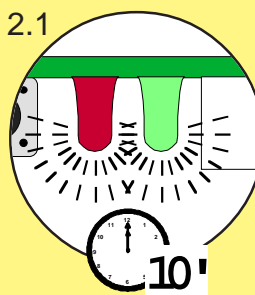

2.2

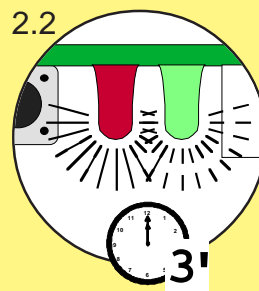

2.3

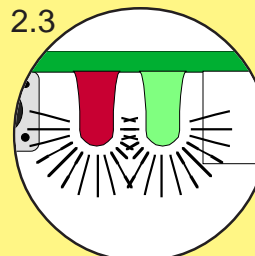

3

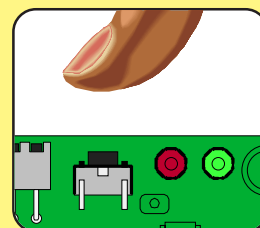

4

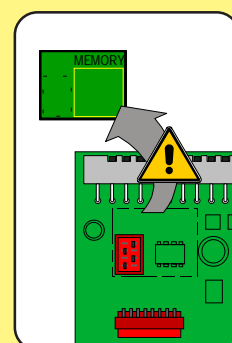

ITALIANO

Nell'esempio viene montata una scheda AF43sM sull'automazione del cancello scorrevole, mentre su ogni basculante è montato un normale ricevitore monocanale.

Ogni utente (famiglia) comanda, con lo stesso trasmettitore (codice), sia il cancello d'ingresso al condominio che la propria basculante;

ENGLISH

In the example, an AF43sM board is fitted on the automated device of the sliding gate, whilst each garage door is fitted with a regular single-channel receiver.

Each user (family) controls both the entrance gate and his own garage door using the same transmitter (code);

FRANCAIS

L'exemple montre comment monter une carte AF43sM sur la motorisation du portail et un récepteur normal à un seul canal sur chaque porte basculante.

Chaque utilisateur (famille) commande le portail d'entrée de l'immeuble et sa porte basculante avec le même émetteur (code);

DEUTSCH

Im Beispiel wird eine Karte AF43sM in eine Automatiksteuerung eines Schiebetors eingebaut. Alle Kipptore dagegen haben einen normalen Einkanalempfänger.

Jeder Benutzer (Familie) steuert mit dem gleichen Sender (Code) sowohl das Einfahrtstor vom Wohnhaus, als auch das eigene Kipptor.

ESPAÑOL

En el ejemplo se instala una tarjeta AF43sM en la automatización de la verja corredera, mientras en cada puerta basculante se instala un normal receptor monocanal.

Cada usuario (familia) ordena, con el mismo transmisor (código), tanto la verja de entrada al edificio como su propia puerta basculante;

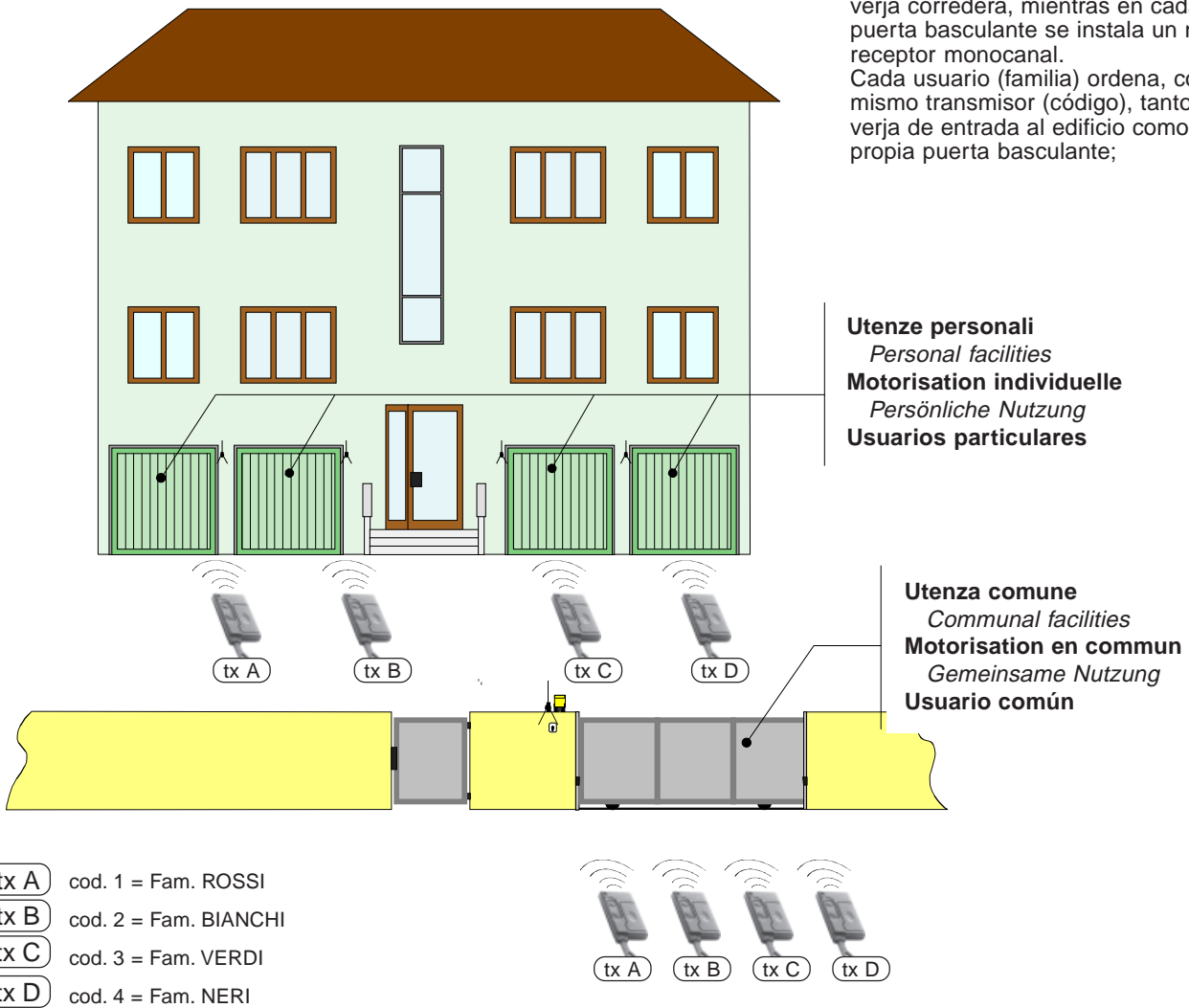

Tutti i dati riportati nel presente libretto sono indicativi. La CAME s.p.a. si riserva di apportare eventuali modifiche inerenti all'evoluzione tecnologica dei prodotti.

All data mentioned in the present booklet are for information only. CAME SPA reserves the right to introduce changes relating to technological improvements of the products.

Toutes les données mentionnées dans le livret sont indicatives. CAME se réserve le droit d'apporter des modifications éventuelles par rapport à l'évolution technologique des produits.

Alle in der vorliegenden Beschreibung angegebenen Daten dienen nur der information. CAME S.P.A. behält sich technische Änderungen vor.

Todos los datos de este libretto son indicativos. CAME s.p.a. se reserva el derecho de aportar las modificaciones producidas por la evolución tecnológica de los productos.



® CAME S.P.A. ITALIA
Via MARTIRI DELLA LIBERTÀ, 15
31030 DOSSON DI CASIER
TREVISO

internet
www.came.it
e-mail
info@came.it

