







Special 301, 302, 303, 304, 305, 311, 315

Notentriegelung		Bei der Montage ist die Anleitung des Antriebs unbedingt zu berücksichtigen. Besonders die Sicherheitshinweise sind zu beachten!	D
Emergency unlocking device		When mounting please observe by all means the installation instructions of the operator. Pay special attention to the safety advice!	GB
Déclenchement d'urgence		Lors du montage, il faut absolument tenir compte des instructions concernant l'opérateur. Il est particulièrement important de respecter les consignes de sécurité!	F
Noodontkoppeling		Bij de montage moet de montage- bedieningshandleiding van de aandrijving in acht worden genomen. In het bijzonder dienen de veiligheidsinstructies te worden opgevolgd!	NL
Sblocco di emergenza		Per i lavori di montaggio osservare sempre le istruzioni di montaggio fornite in dotazione con la motorizzazione. Osservare in particolare gli avvisi di sicurezza!	I
Desbloqueo de emergencia		Al realizar el montaje es estrictamente necesario tener en cuenta las instrucciones del operador. ¡Hay que observar especialmente las indicaciones de seguridad!	E
Destravamento de emergência		Na montagem é indispensável considerar o manual do accionamento. Especialmente as indicações de segurança devem ser observadas!	P
Nödulösning		Vid monteringen skall anvisning för drivningen ovillkorligen beaktas. Speciellt säkerhetsanvisningarna skall beaktas!	S
Nødåpning		Det er tvingende nødvendig å følge bruksanvisningen for drivenheten under monteringen. Særlig sikkerhetsinstruksene må følges!	N
Vészhelyzeti kireteszelés		A szereléskor feltétlenül tekintetbe kell venni a kapuműködtető útmutatóját. Különösen a biztonságtechnikai útmutatásokat kell követni!	H
Zasilno odpahovanje		Pri montaži je potrebno brezpogojno upoštevati navodila pogona. Posebej se morajo upoštevati varnostna navodila!	SLO
Nouzové odblokování		Při montáži bezpodmínečně dodržujte montážní návod pro pohon. Zvláště pak dodržujte bezpečnostní pokyny!	CZ
Ryglowanie awaryjne		Podczas montażu należy koniecznie przestrzegać instrukcji napędu, a w szczególności wskazówek bezpieczeństwa!	PL
Avarinis atsklendimas		Montuodami būtina laikytis pavaros naudojimo vadovo. Ypatingai atkreipti dėmesį į saugos nuorodas!	LT
Аварийная разблокировка		Во время проведения монтажа необходимо принимать во внимание положения руководства по работе привода. В особенности следует учитывать указания по технике безопасности!	RUS
Nødopløsning		Ved montagen skal man ubetinget være opmærksom på vejledningen til drevet. Bemærk i særdeleshed sikkerhedshenvisninger!	DK



1. Special 301, 302, 303, 304, 305, 311, 315

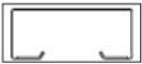
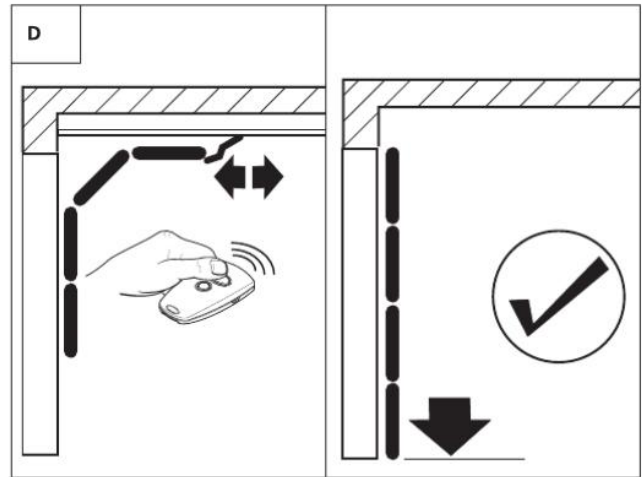
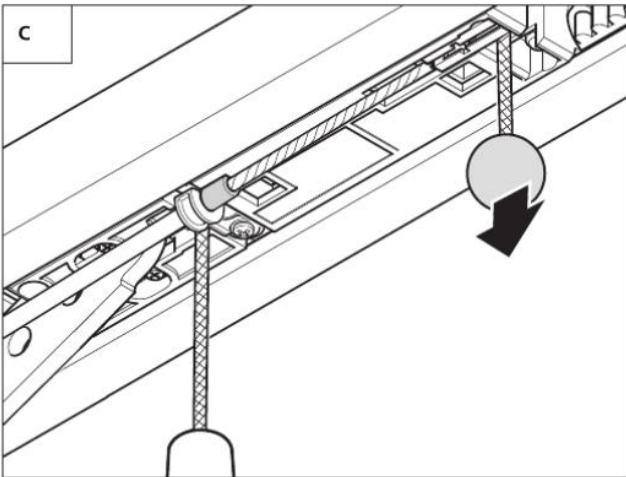
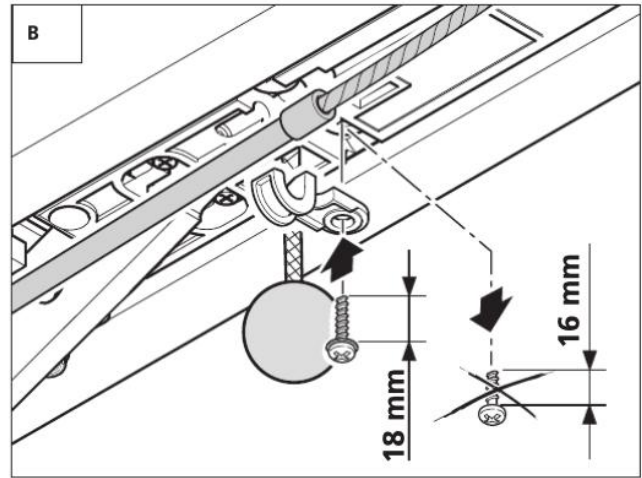
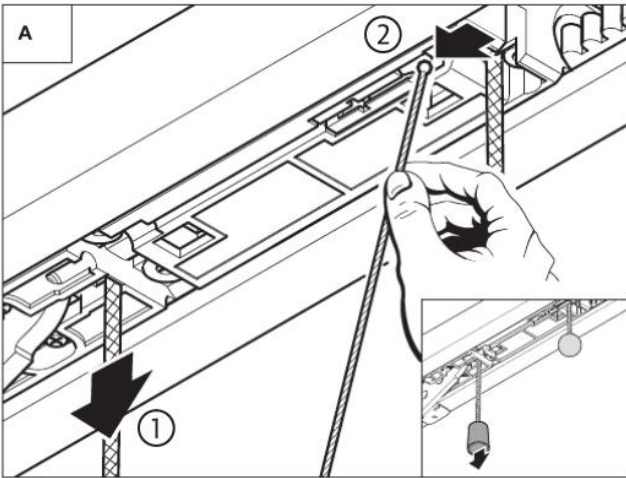

2. Special 301, 302, 303, 304, 305, 311, 315

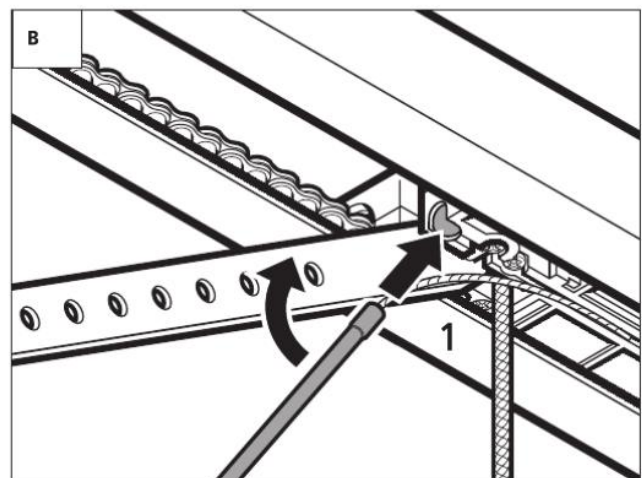
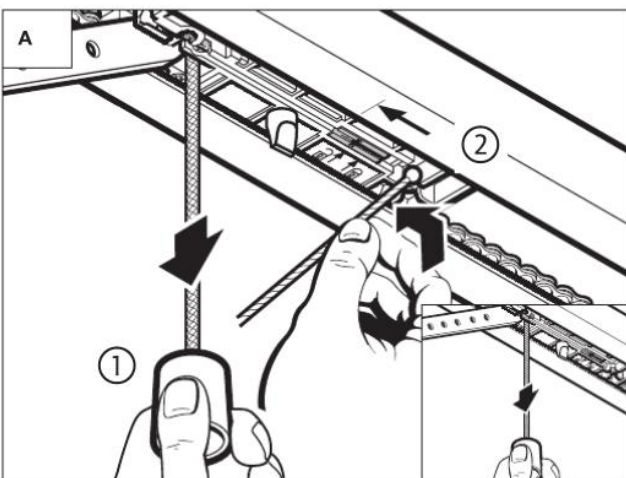

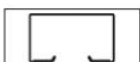
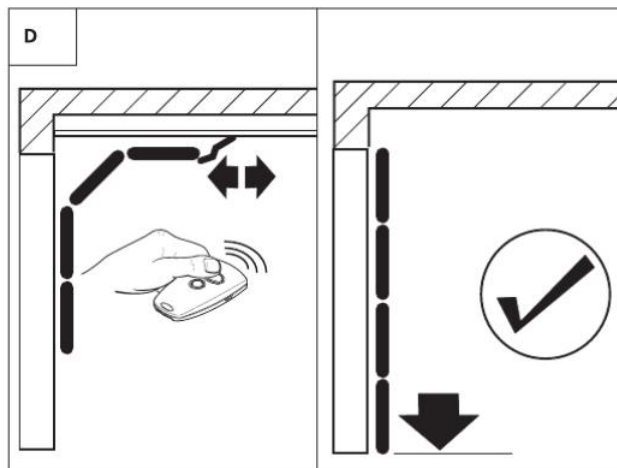
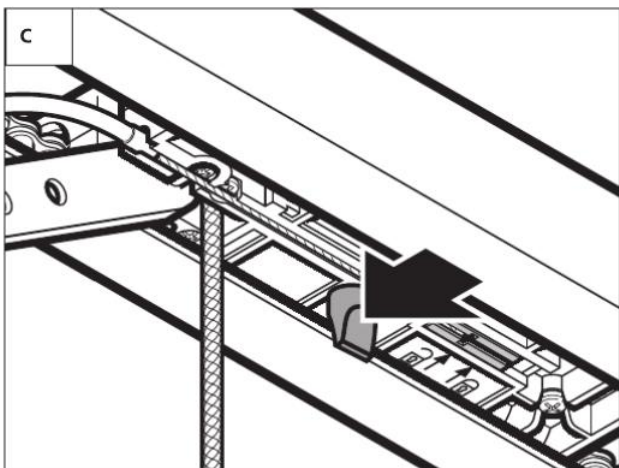

3. Special 301, 302, 303, 304, 305, 311, 315

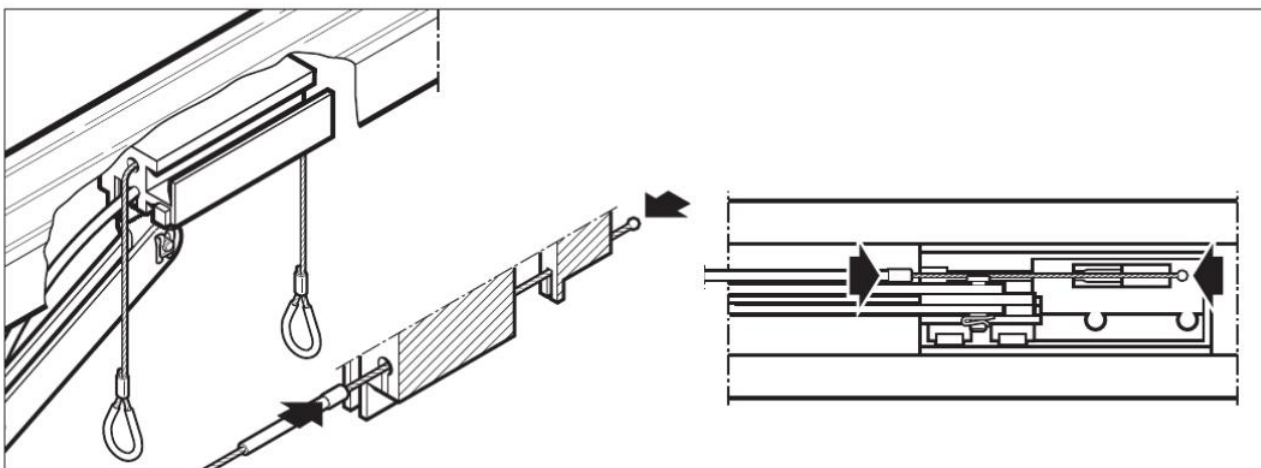

Special 301

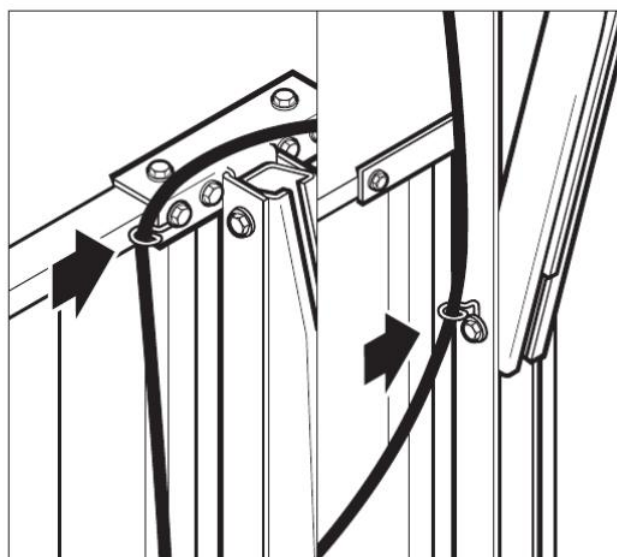
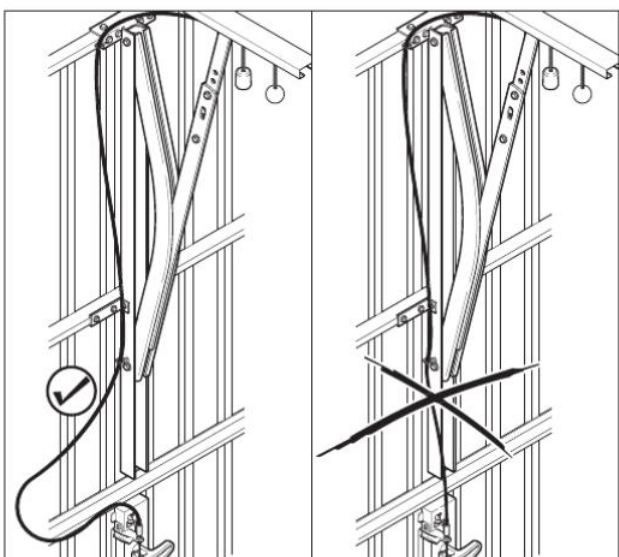

Special 301

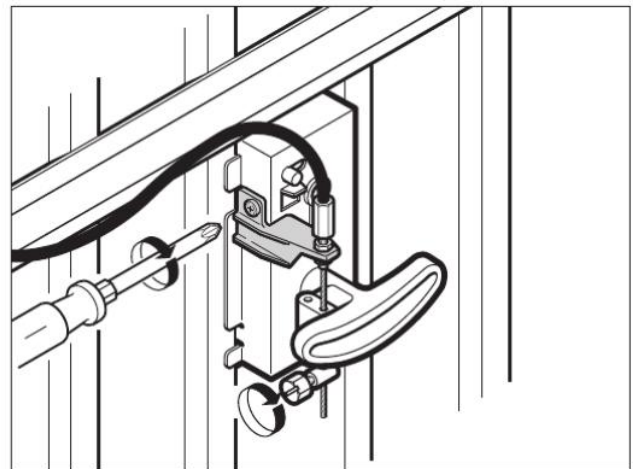
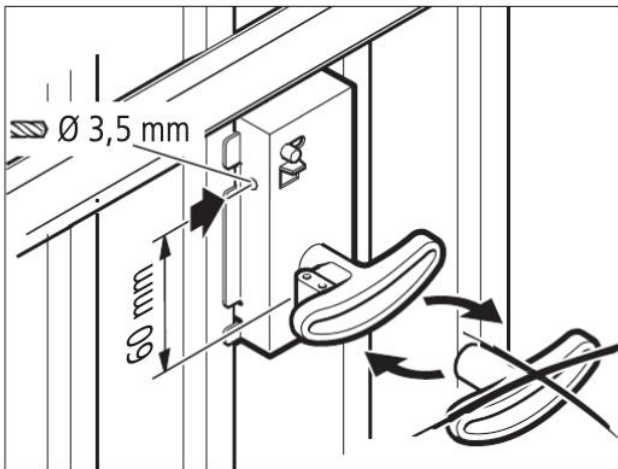

Special 302, 315

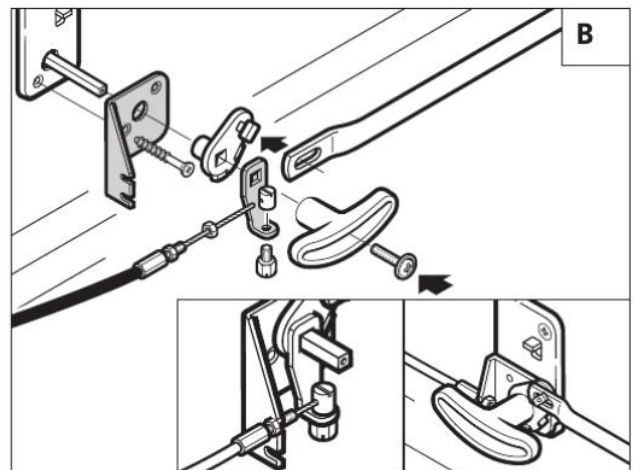
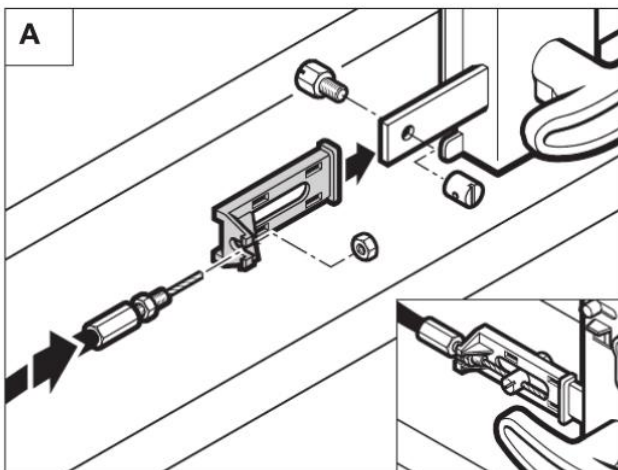
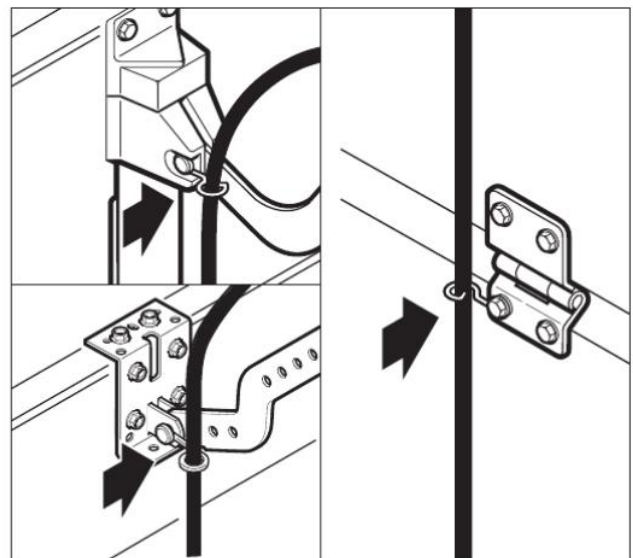
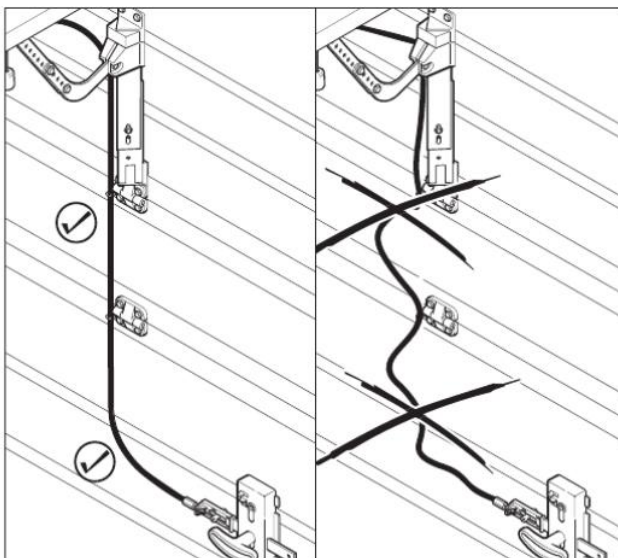

Special 303

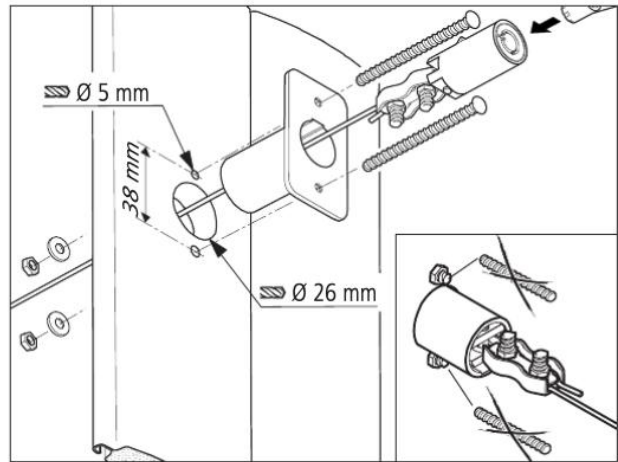
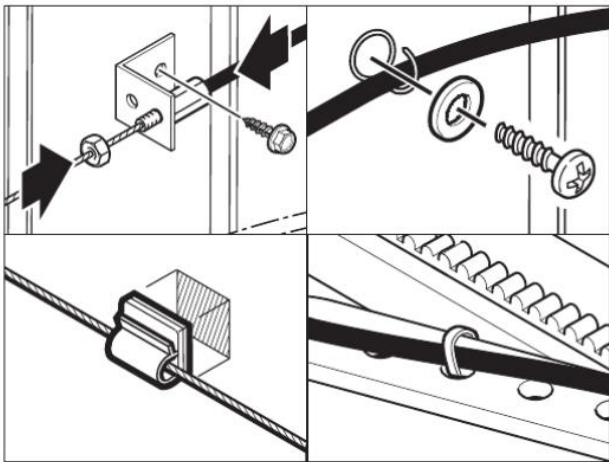
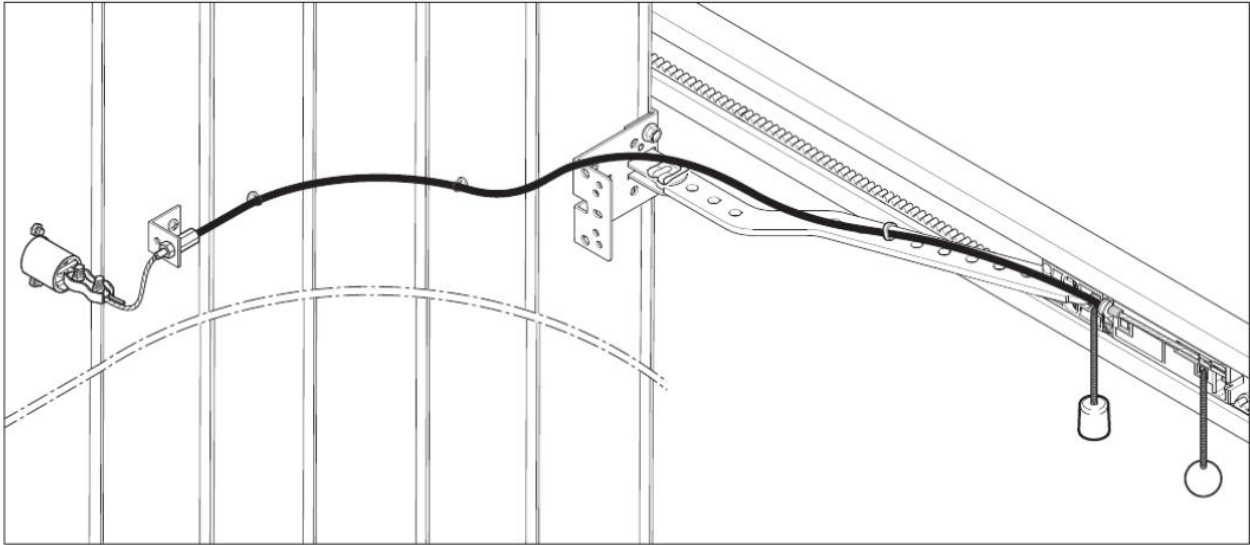

Special 304

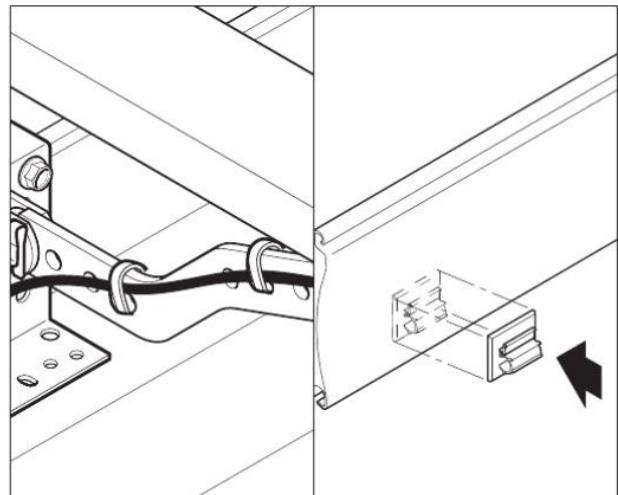
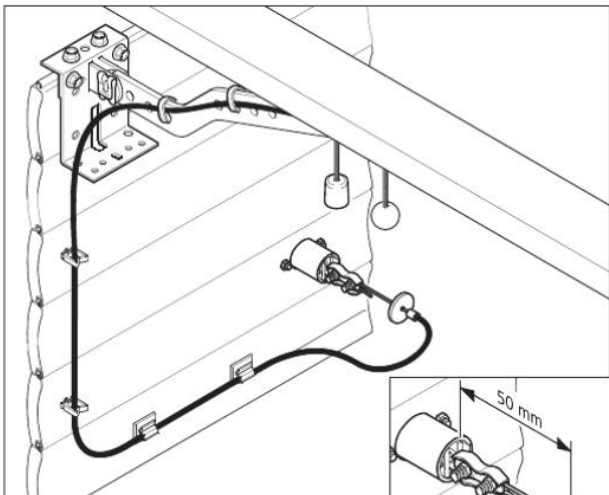

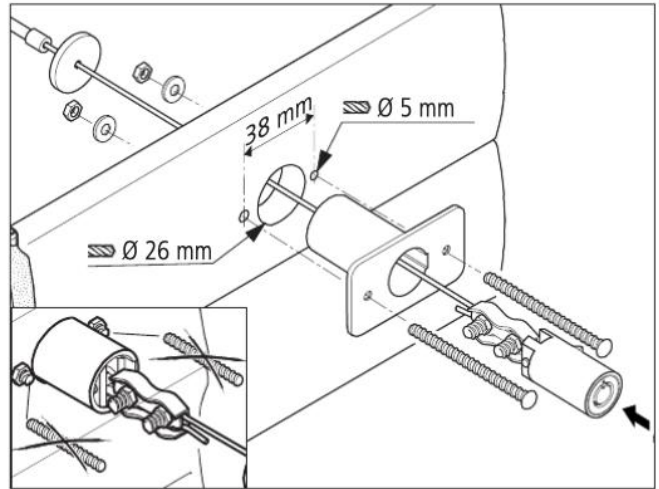
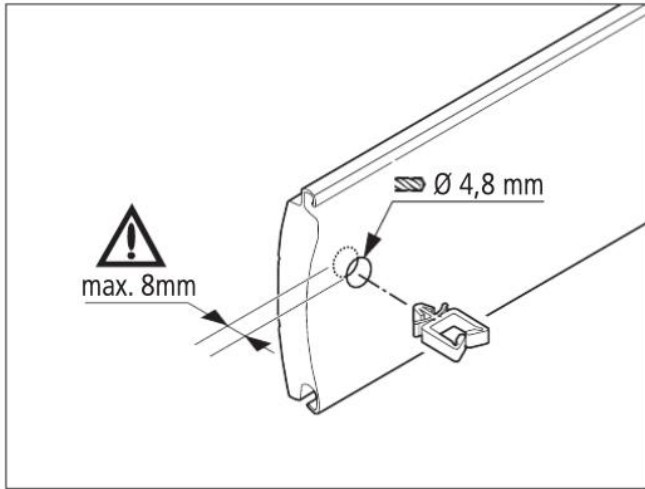

Special 305

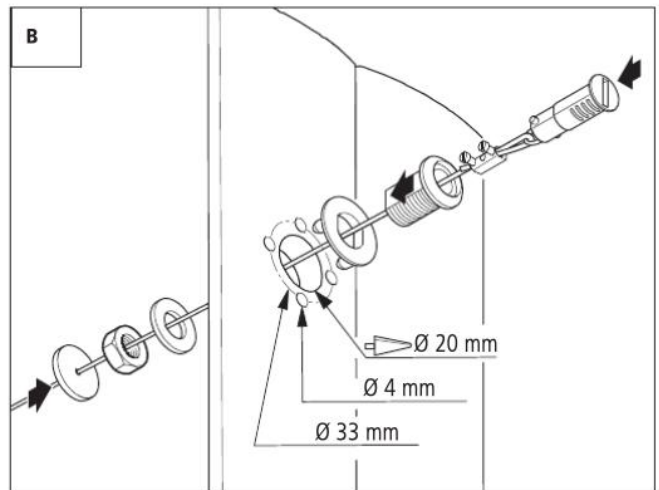
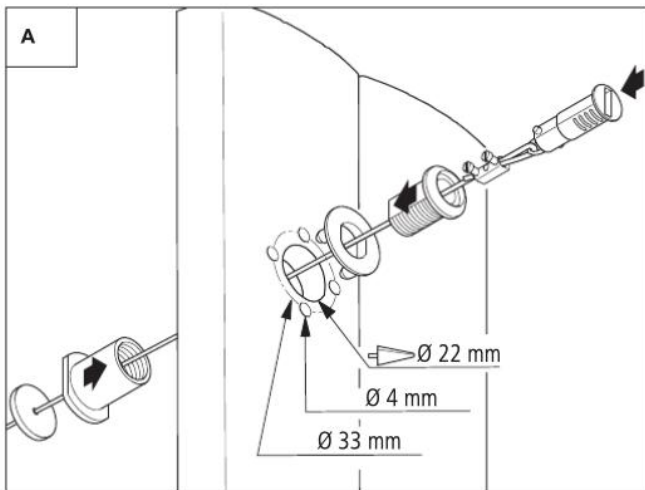

Special 304 + Comfort 515

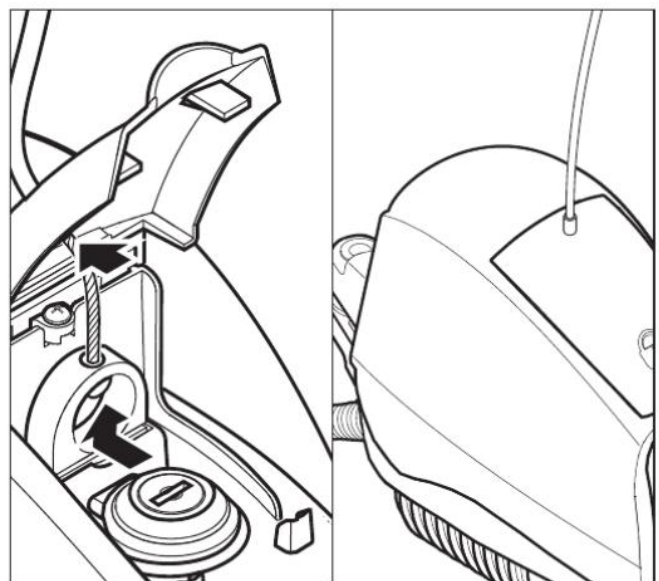
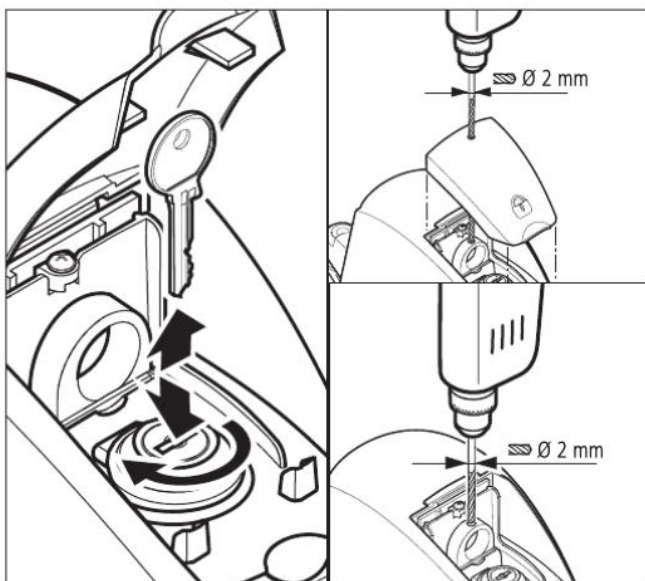

Special 311

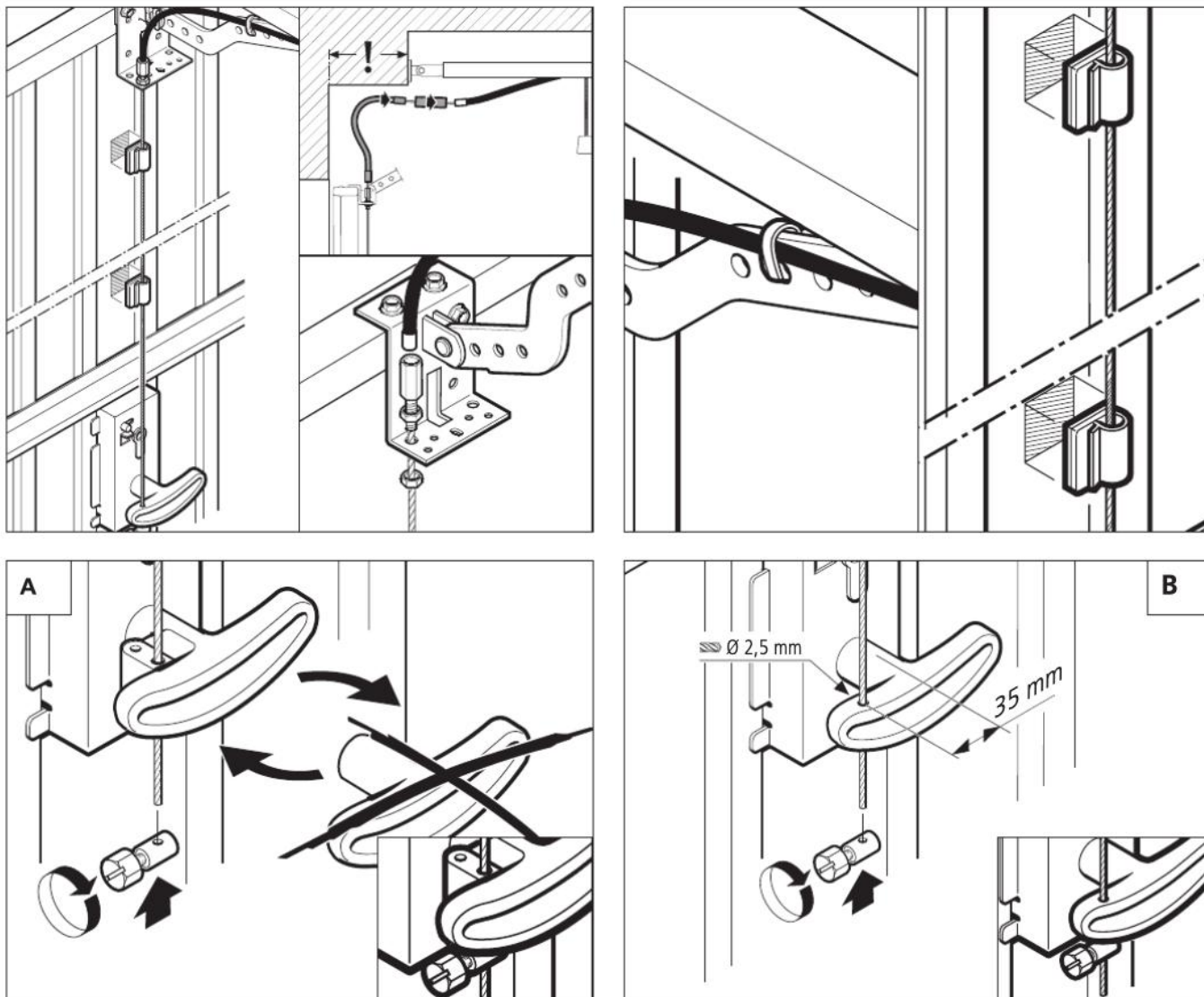

Special 301, 302, 303, 304, 305, 311, 315

Ⓓ Funktionskontrolle

Nach erfolgter Montage, muss die Notentriegelung geprüft werden.

Die Prüfung muss alle 6 Monate wiederholt werden.

ⒸⒼ Functional check

After installation is carried out, the emergency unlocking device must be checked. This inspection needs to be repeated every 6 months.

Ⓕ Contrôles de fonction

Après le montage, le déclenchement d'urgence doit être vérifié. Il faut répéter ce contrôle tous les 6 mois.

ⒸⓃ Functiecontrole

Na montage dient de noodontkoppeling te worden gecontroleerd.

Deze controle moet om de 6 maanden worden herhaald.

Ⓘ Controllo di funzionamento

Una volta conclusa l'installazione deve essere controllato lo sblocco di emergenza.

Questo controllo va ripetuto una volta ogni sei mesi.

Ⓔ Control del funcionamiento

Una vez efectuado el montaje, se tiene que comprobar el desbloqueo de emergencia. Hay que repetir la comprobación cada seis meses.

Ⓖ Controllo de funcionamento

Depois de a montagem estar concluída, o destravamento de emergência tem de ser verificado.

A verificação deve ser repetida a cada 6 meses.

Ⓒ Funktionskontroll

Efter monteringen ska nödutlösningen kontrolleras.

Denna kontroll ska upprepas var 6. månad.

Ⓒ Funktionskontroll

Når monteringen er avsluttet, må nødåpningen kontrolleres.

Kontrollen må gjentas hver 6. måned.

Ⓕ Működésellenőrzés

A sikeres összeszerelés után ellenőrizze a vészhelyzeti kireteszelést.

Az ellenőrzést hathavonta el kell végeznie.

(SLO) Funkcijska kontrola

Po zaključeni montaži, preverite delovanje zasilnega odpahovanja.

Takšno preverjanje morate opraviti vsakih 6 mesecev.

(CZ) Kontrola funkce

Po provedení montáži se musí zkontrolovat nouzové odblokování.

Kontrola se musí každých 6 měsíců opakovat.

(PL) Kontrola działania

Po zakończeniu montażu należy sprawdzić funkcję ryglowania awaryjnego.

Badanie należy powtarzać co 6 miesięcy.

(LT) Funkcinė kontrolė

Pabaigus montuoti reikia patikrinti avarinį atsklendimą.

Bandymą reikia kartoti kas 6 mėnesius.

(RUS) Контроль правильности функционирования

После выполнения монті

Проверку следует повторять через каждые 6 месяцев.

(DK) Funktionskontrol

Efter montering, skal nødopløsningen kontrolleres.

Denne kontrol skal gentages hver 6. måneder.

DEUTSCH Urheberrechtlich geschützt.
Nachdruck, auch auszugsweise, nur mit unserer Genehmigung.
Änderungen, die dem technischen Fortschritt dienen, vorbehalten.

ENGLISH Copyright.
No part of this manual may be reproduced without our prior written approval.
We reserve the right to alter details in the interests of progress.

FRANÇAIS Copyright
Toute reproduction même partielle est interdite sans notre autorisation.
Tous changements de constructions permis par l'évolution des techniques réservés.

NEDERLANDS Door de auteurswet beschermd.
Niets uit deze uitgave mag worden verveelvoudigd en/of openbaar gemaakt door middel van druk, fotocopie, microfilm of op welke andere wijze dan ook zonder voorafgaande toestemming van de uitgever.
Technische wijzigingen voorbehouden.

ITALIANO Diritti d'autore riservati.
Riproduzione, anche parziale, previa solo nostra autorizzazione.
La Ditta si riserva la facoltà di apportare modifiche al prodotto in base al progresso tecnologico.

ESPAÑOL Copyright.
Prohibida la reproducción íntegra o parcial sin nuestra autorización.
Reservado el derecho a modificaciones en el interés del perfeccionamiento técnico.

PORTUGUES Reservados os direitos de autor.
Reprodução, mesmo parcialmente, só com a nossa autorização.
Sujeito a alterações que sirvam a evolução técnica.

SVENSKA Upphovsrättsskyddad.
Eftertryck, även delvis, endast med vårt tillstånd.
Med förbehåll för ändringar som tjänar den tekniska utvecklingen.

NORSK Beskyttet opphavsrett.
Ettertrykk - også i utdrag - bare med vår tillatelse.
Endringer, som tjener den tekniske utviklingen, forbeholdes.

MAGYAR A jelen anyagot szerzői jog védi.
Kinyomatni, akárcsak kivonatosan is, csak engedélyünkel szabad.
A műszaki haladás célját szolgáló módosítások jogát fenntartjuk.

SLOVENSKO Zaščiteno z avtorskim pravom.
Ponatis, tudi v izvlečkih, je dovoljen le z našim dovoljenjem.
Spremembe, ki služijo tehnični izboljšavi proizvoda, so pridržane.

ČESKY Chráněno autorskými právy
Dotisk, i jen částí, možný pouze s naším svolením.
Změny, které slouží technickému pokroku, vyhrazeny.

POLSKI Chroniona prawem autorskim.
Przy wykonywaniu przedruku, także fragmentów, konieczne jest uzyskanie naszej zgody.
Zastrzegamy sobie prawo do wprowadzenia zmian wynikających z postępu technicznego.

LIETUVIŲ KALBA Autorinės teisės saugomos.
Kopijavimas, taip pat ir dalimis, tik su mūsų leidimu.
Galimi technikos pažangos sąlygojami pakeitimai.

Русский Авторские права защищены.
Перепечатка, даже выдержками, только с нашего разрешения.
Мы оставляем за собой право на изменения, служащие техническому прогрессу.

DANSK Ophavsretsligt beskyttet.
Genoptryk, også i uddrag, kun med vores tilladelse.
Ændringer, der tjener den tekniske udvikling, forbeholdes .



85759