

2

Special 301, 302, 311, 315

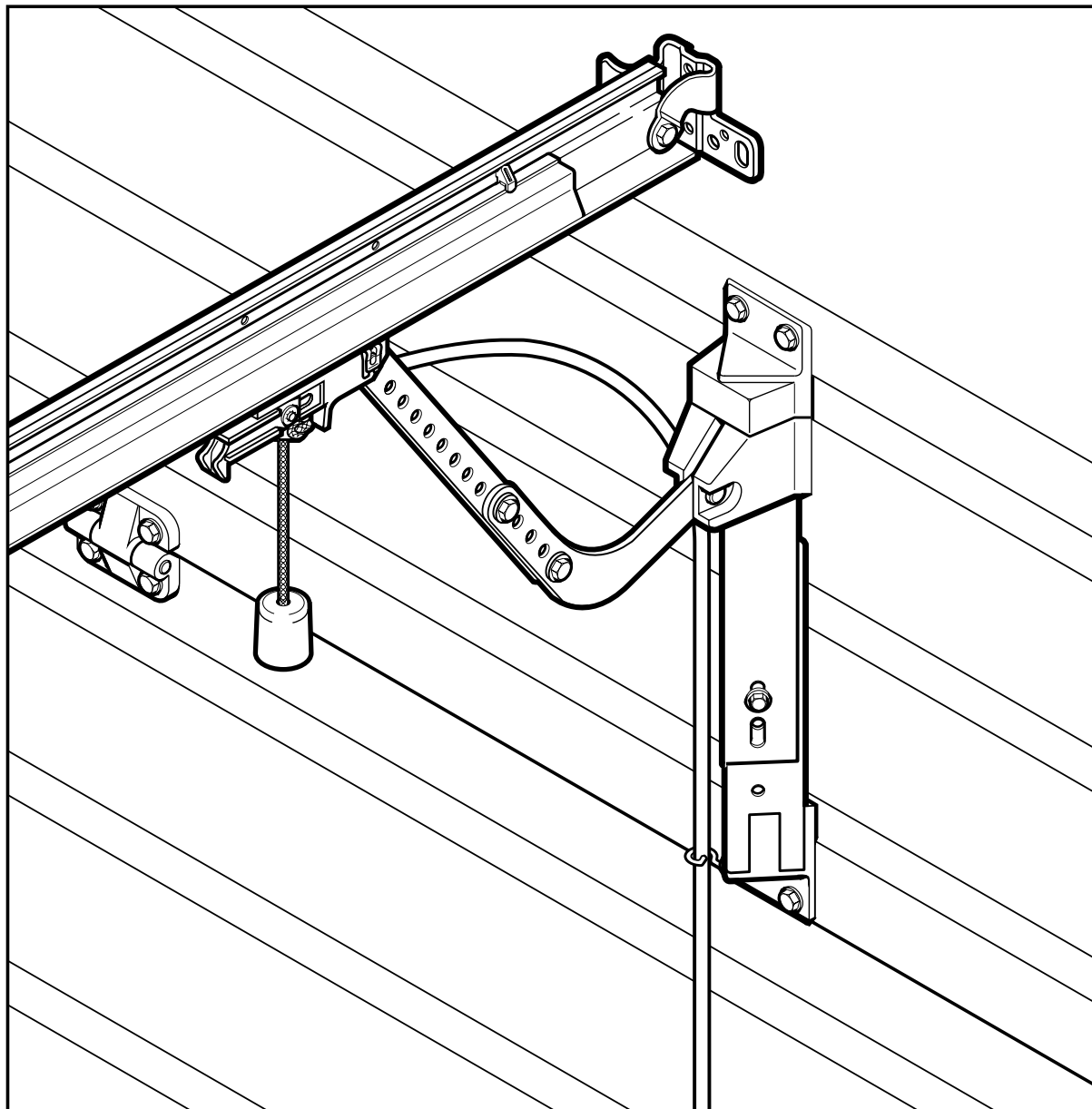

1a

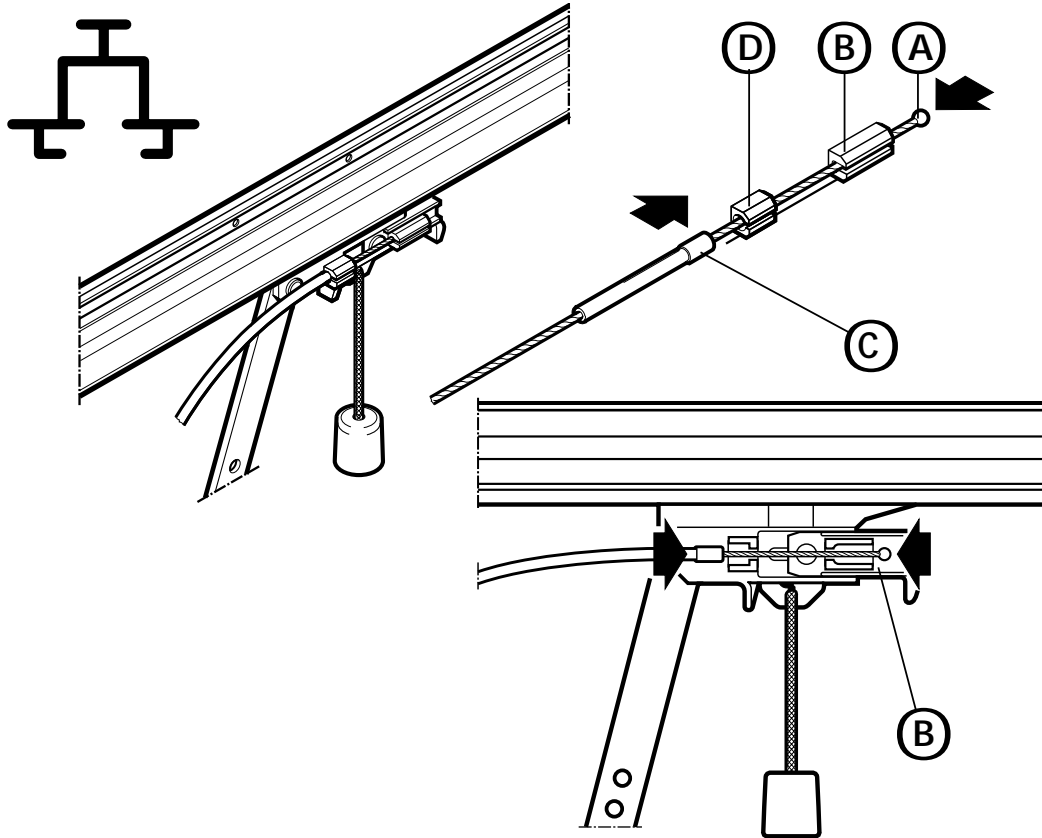

1b

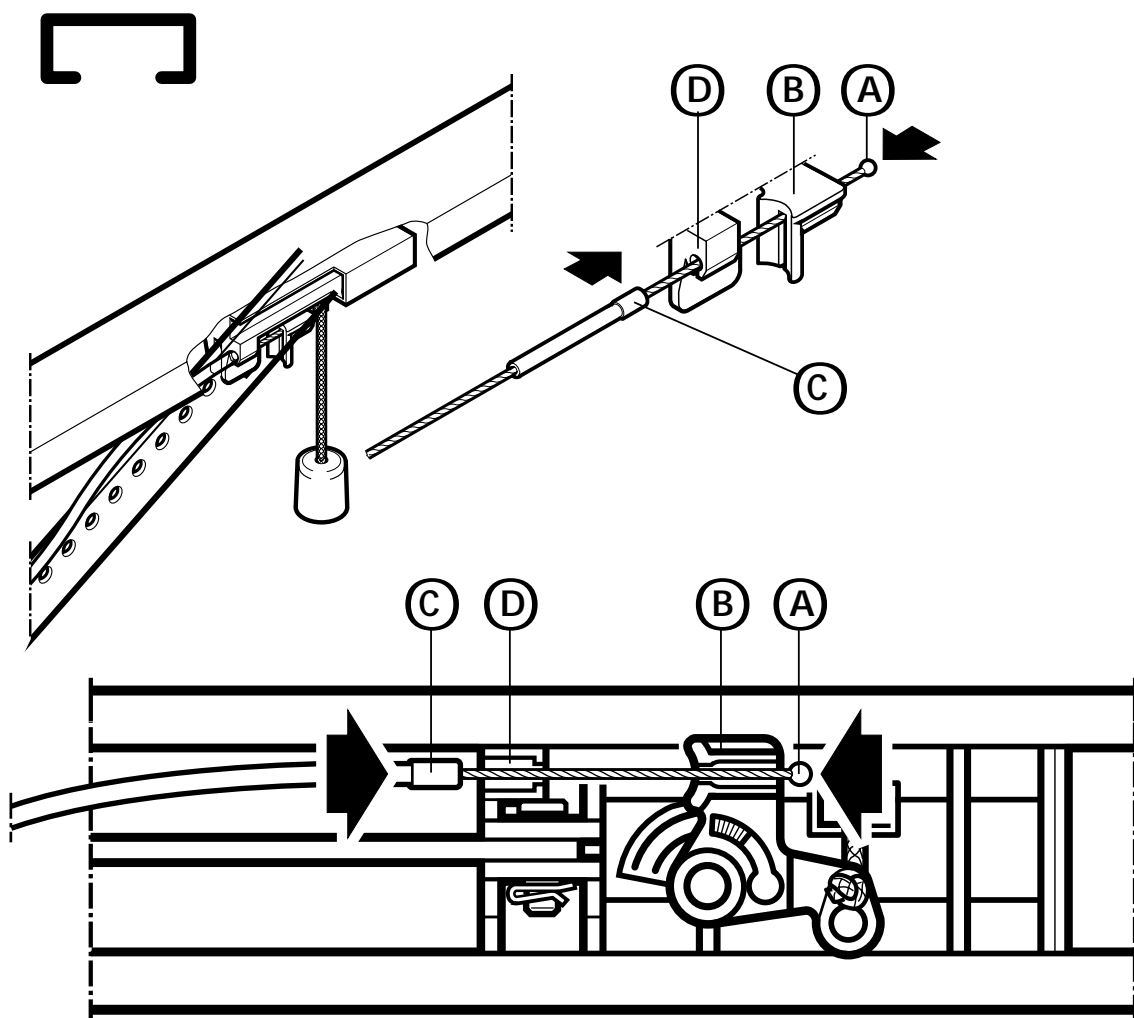

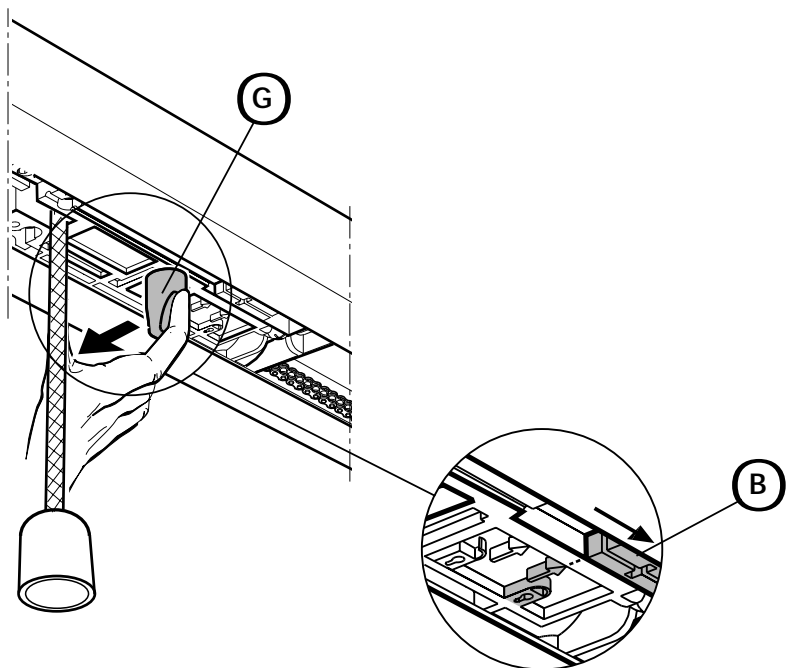
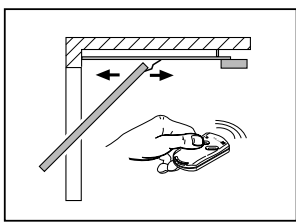
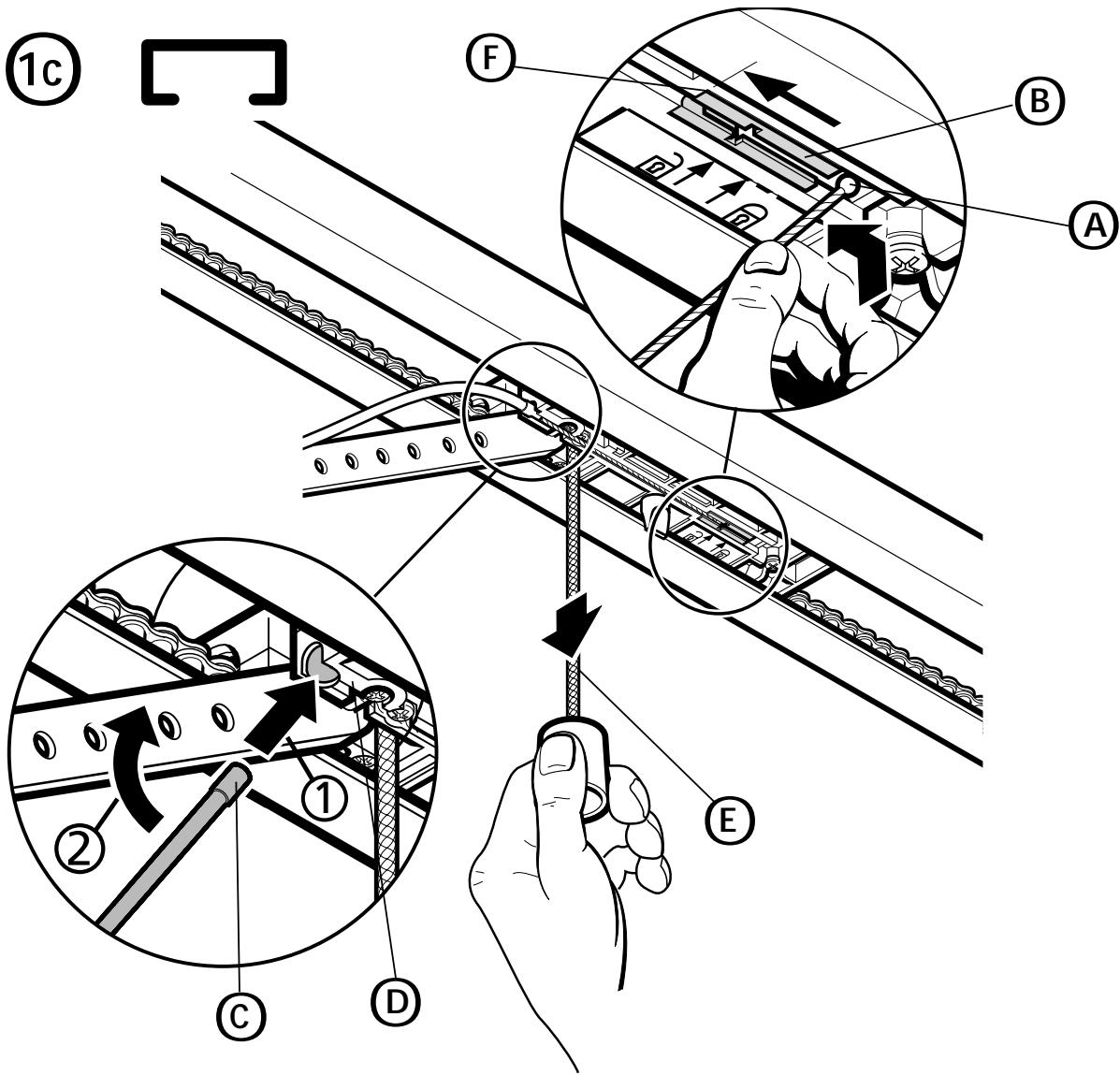

1d

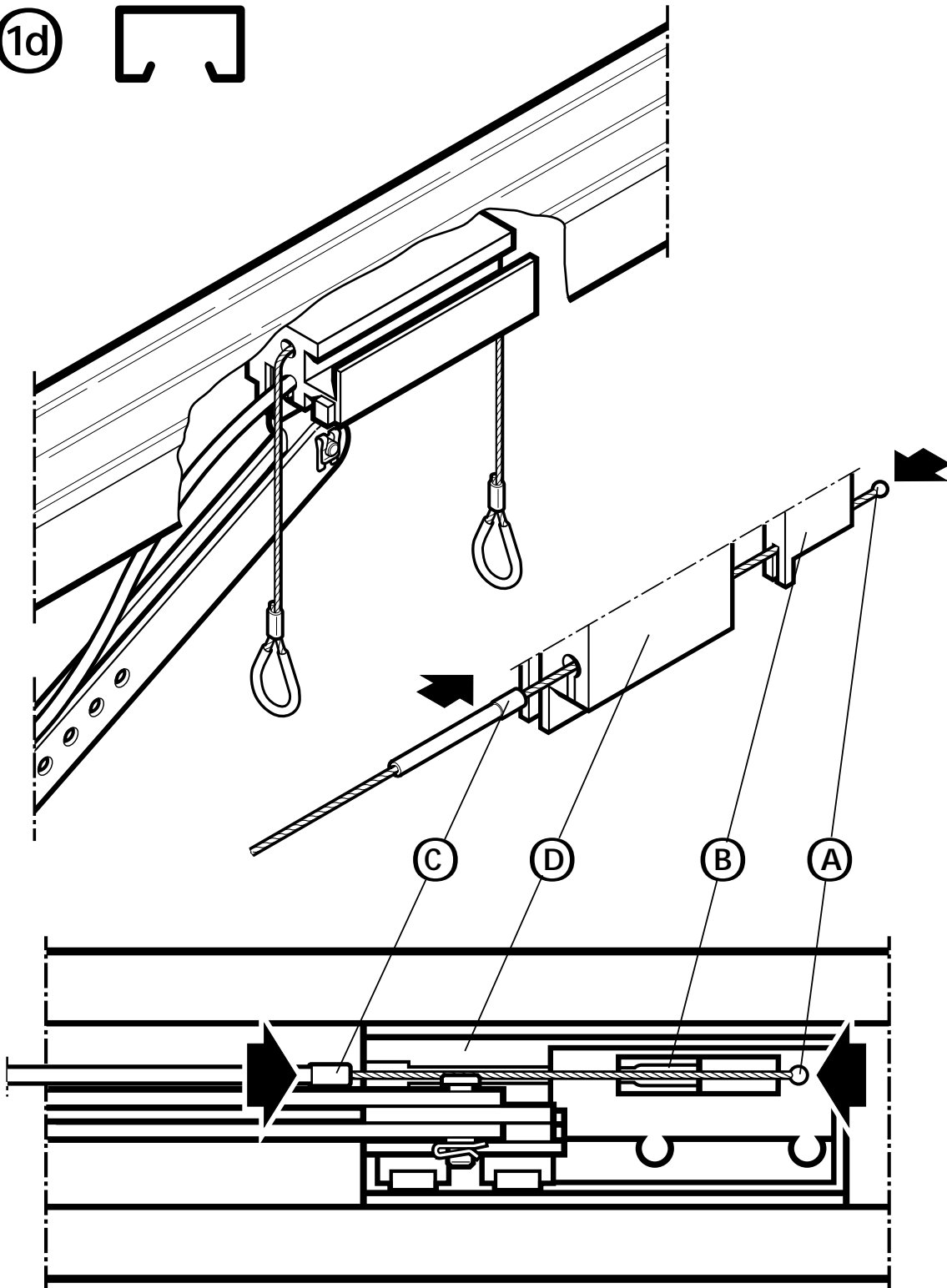

2

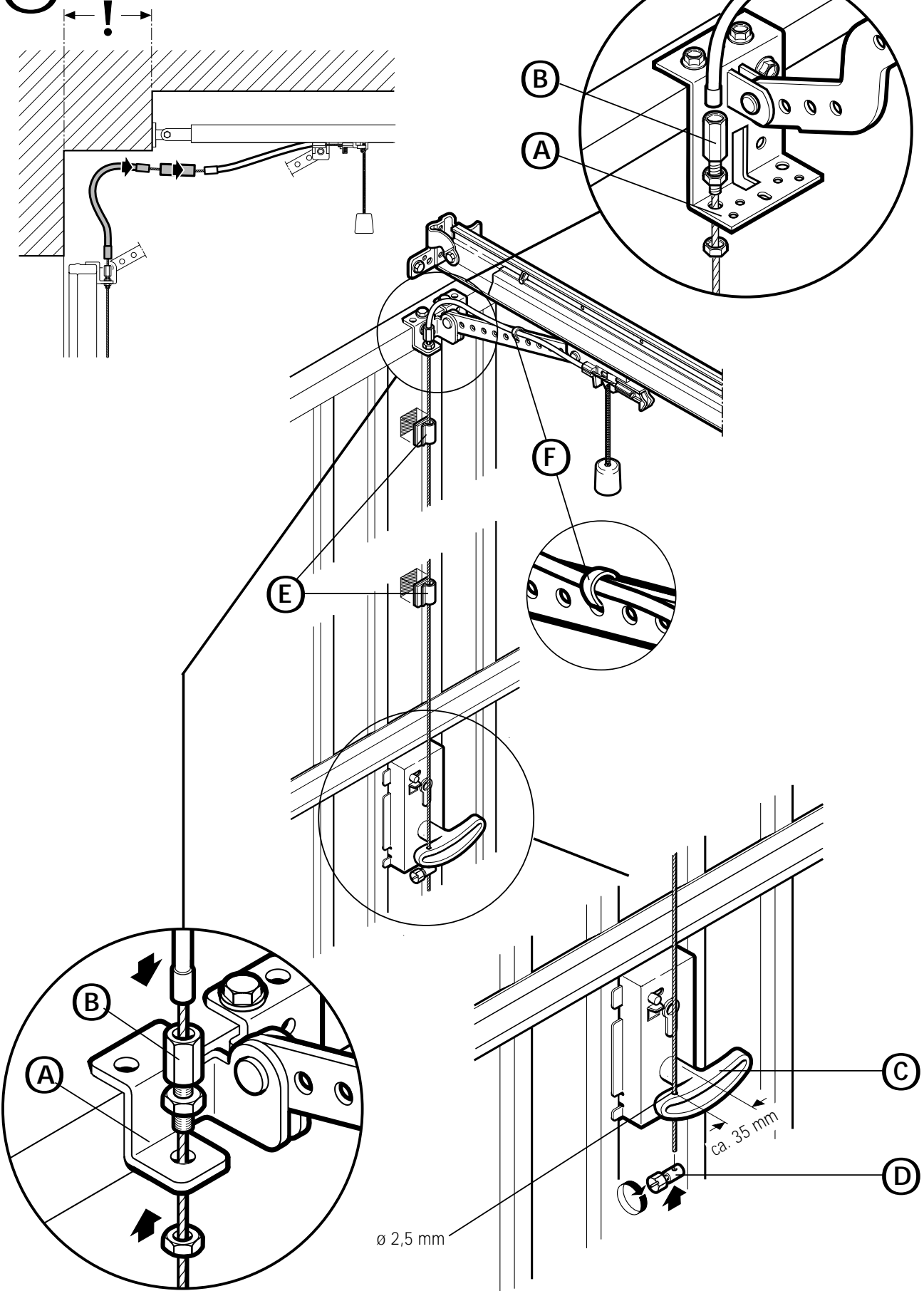

3a

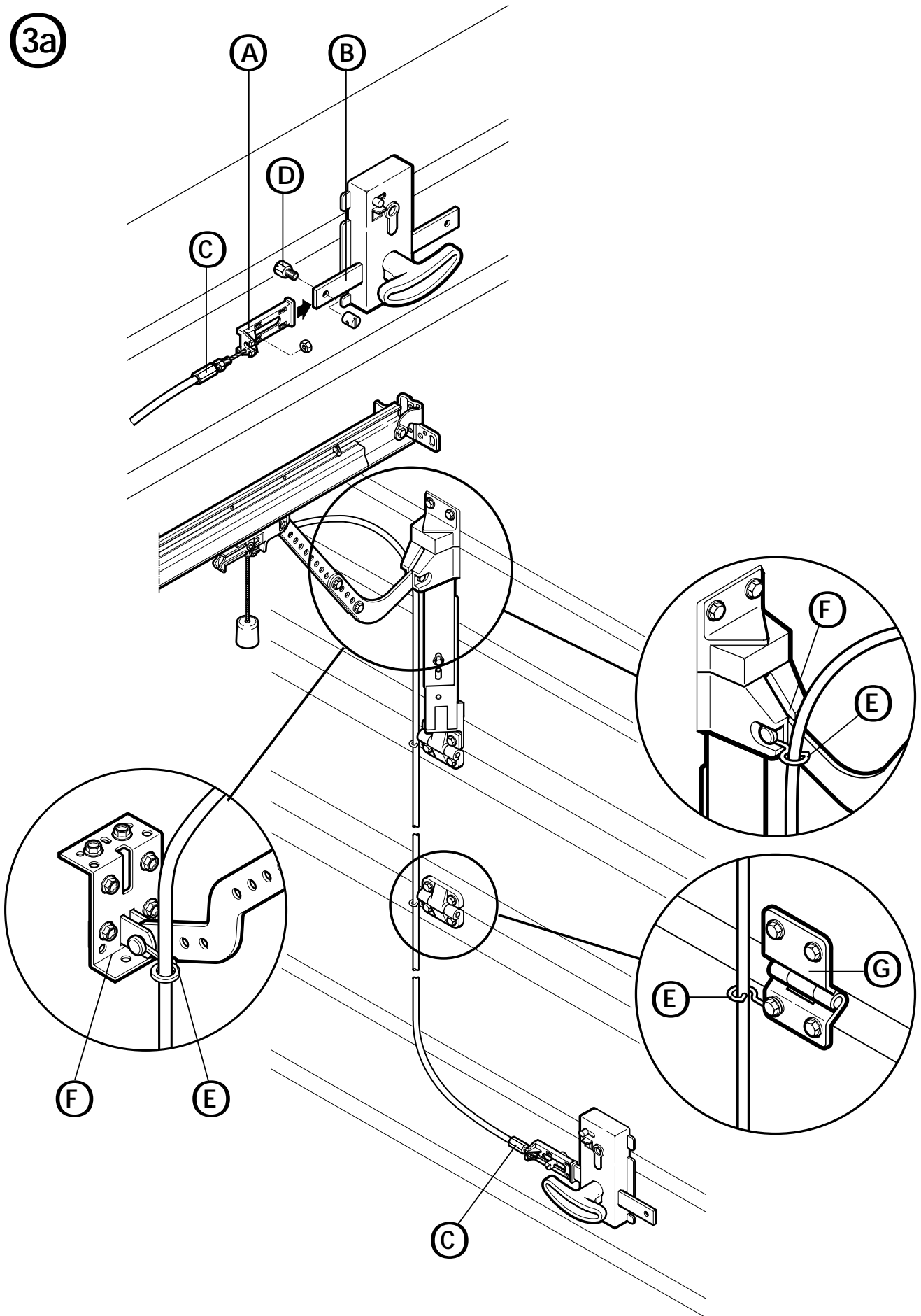

3b

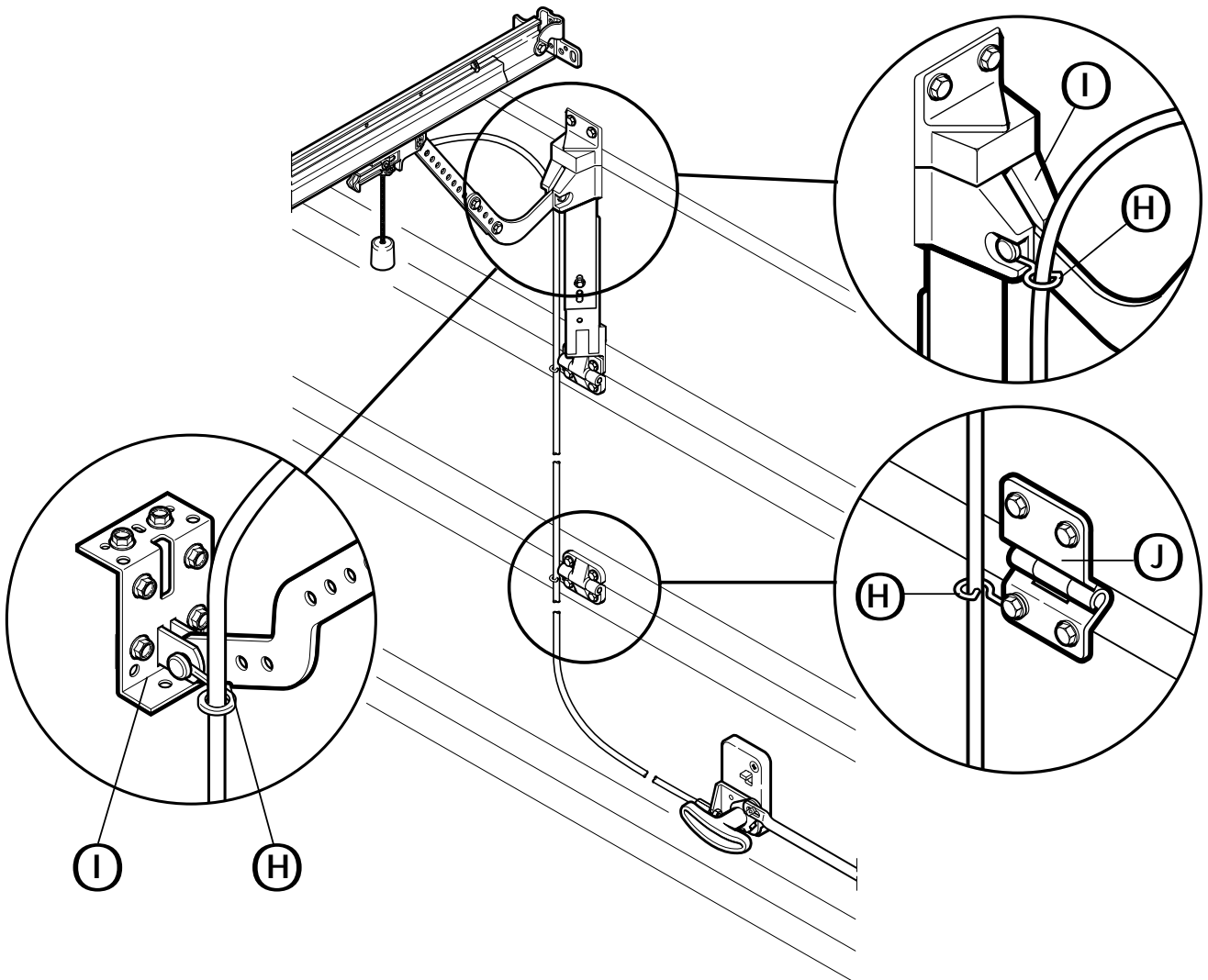
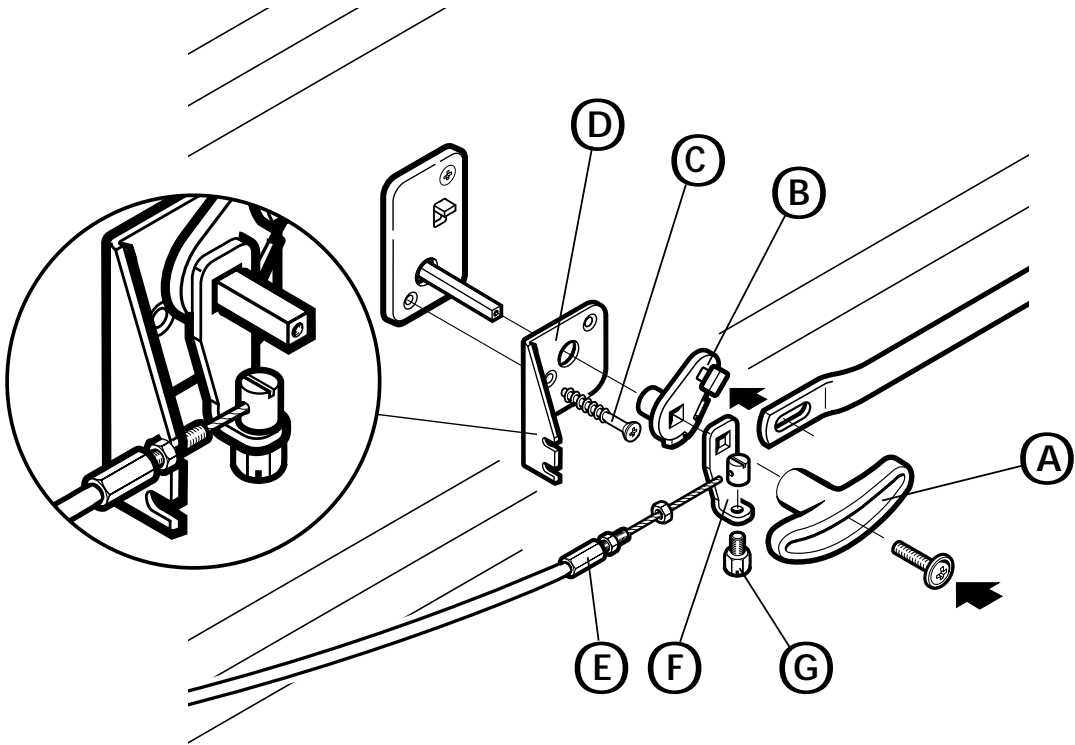

4

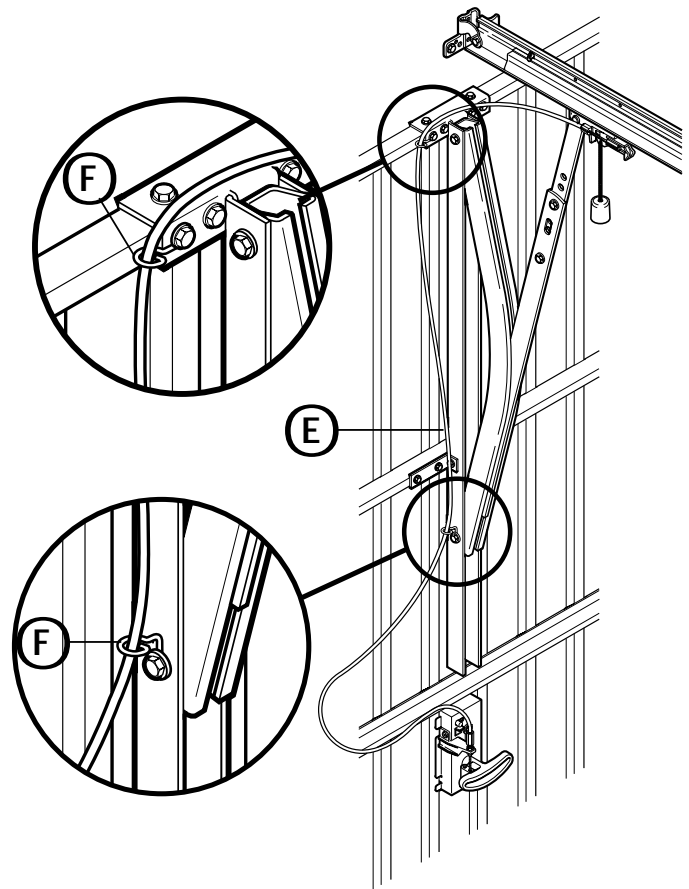
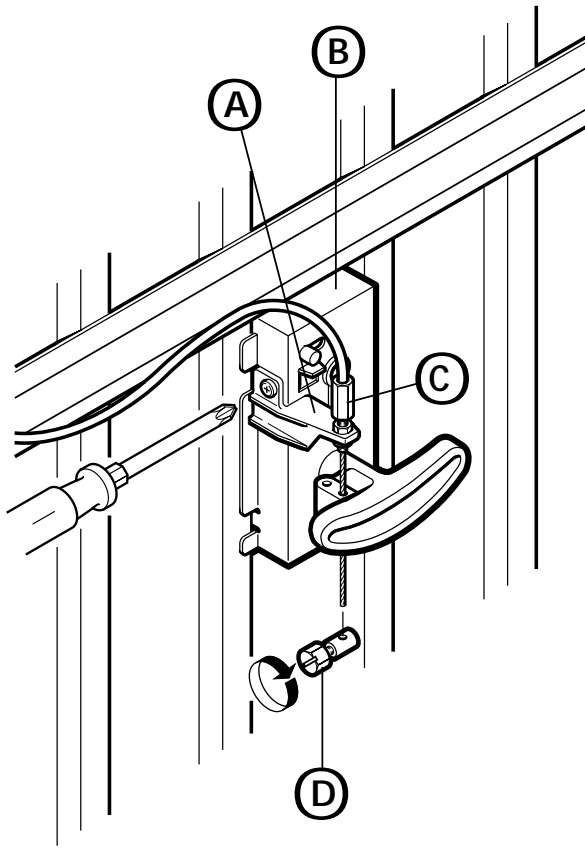

5

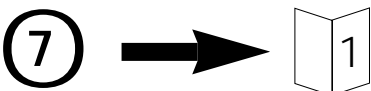
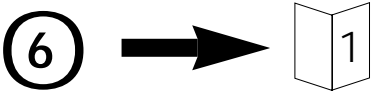
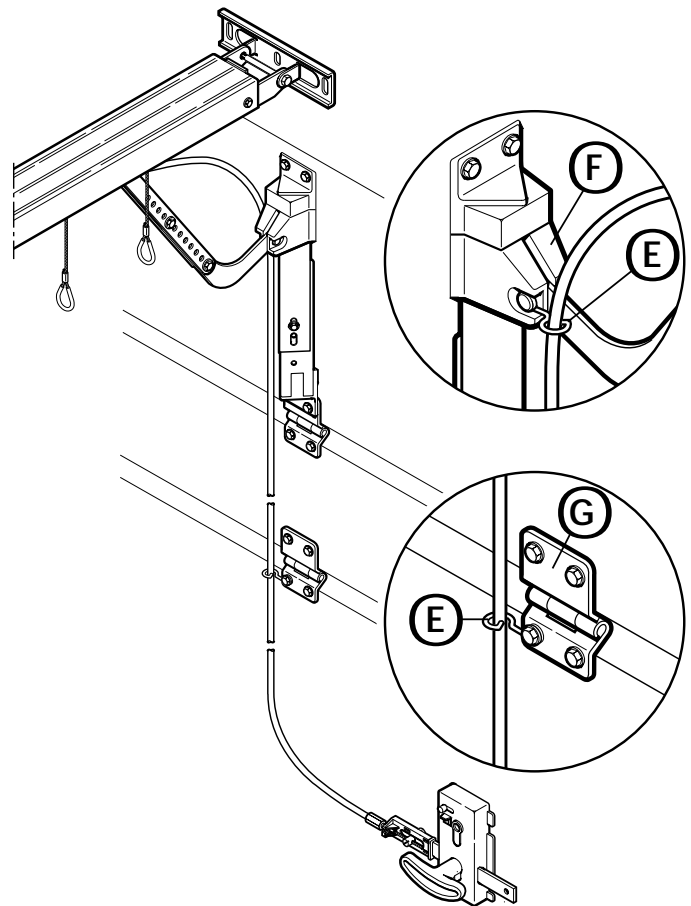
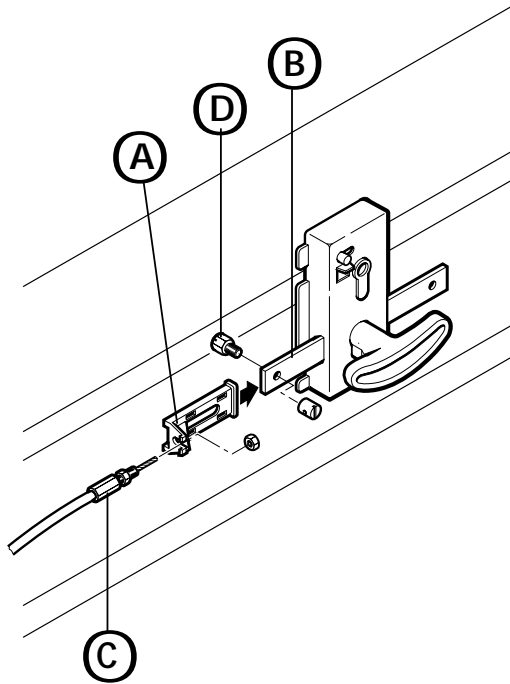

DEUTSCH	Urheberrechtlich geschützt. Nachdruck, auch auszugsweise, nur mit unserer Genehmigung. Änderungen, die dem technischen Fortschritt dienen, vorbehalten.
ENGLISH	Copyright. No part of this manual may be reproduced without our prior written approval. We reserve the right to alter details in the interests of progress.
FRANÇAIS	Copyright Toute reproduction même partielle est interdite sans notre autorisation. Tous changements de constructions permis par l'évolution des techniques réservés.
NEDERLANDS	Door de auteurswet beschermd. Niets uit deze uitgave mag worden verveelvoudigd en/of openbaar gemaakt door middel van druk, fotocopie, microfilm of op welke andere wijze dan ook zonder voorafgaande toestemming van de uitgever. Technische wijzigingen voorbehouden.
ESPAÑOL	Copyright. Prohibida la reproducción íntegra o parcial sin nuestra autorización. Reservado el derecho a modificaciones en el interés del perfeccionamiento técnico.
ITALIANO	Diritti d'autore riservati. Riproduzione, anche solo parziale, previa nostra autorizzazione. La Ditta si riserva la facoltà di apportare modifiche al prodotto che servano allo sviluppo tecnico.
SVENSKA	Upphovsrättsskyddad. Eftertryck, även delvis, endast med vårt tillstånd. Med förbehåll för ändringar som tjänar den tekniska utvecklingen.
NORSK	Beskyttet opphavsrett. Ettertrykk - også i utdrag - bare med vår tillatelse. Endringer, som tjener den tekniske utviklingen, forbeholdes.
DANSK	Beskyttet ophavsret Gengivelse, også i uddrag kun med vor tilladelse. Ændringer forbeholdt.
POLSKI	Prawa autorskie zastrzeżone. Kopiowanie, również fragmentów, tylko za zezwoleniem. Zastrzega się wprowadzanie zmian służących usprawnieniu technicznemu.